

Venus 22 sistemi za izradu staklenih pregradnih vrata

40 kg 80 kg	Staklo 8mm ÷ 10mm	850mm MAX	Meko zatvaranje
----------------	-------------------	--------------	-----------------

PVS VENUS 22 set 1.80m*



		šifra
set	SM	5315

* U prodajnom setu Venus 22 - 1,80m se nalazi gornja šina 1,80m dužine, kao i donji pvc profil

PVS VENUS 22 set 1.67 sa usp.*



		šifra
set	SM	4384

* U prodajnom setu Venus 22S - 1,67m se nalazi gornja šina 1,67m dužine, kao i donji pvc profil.

Tehnički crteži i prikaz montaže mehanizma

PVS VENUS 22 set 1.80m*

Prikaz montaže stopera i montiranja šine na zid

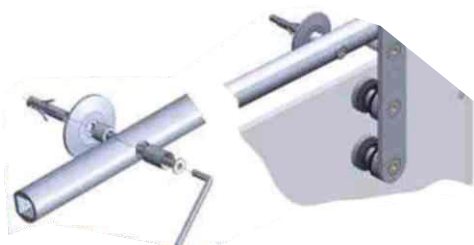



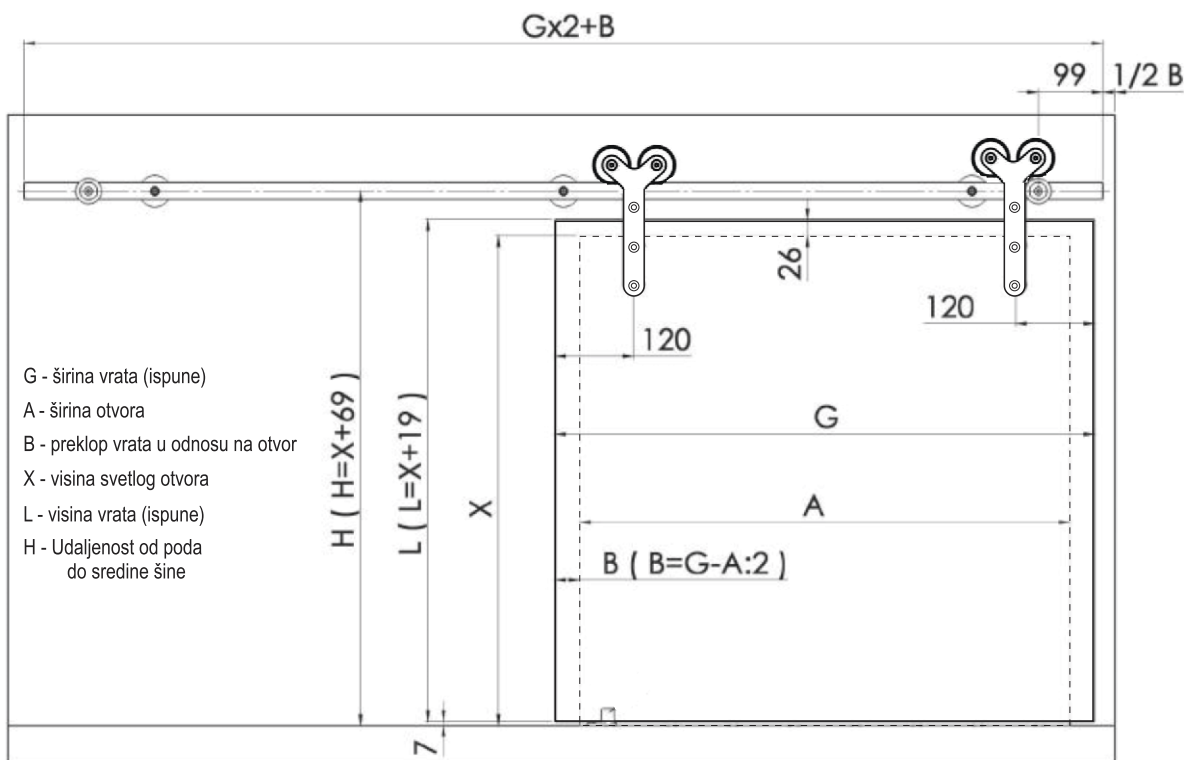
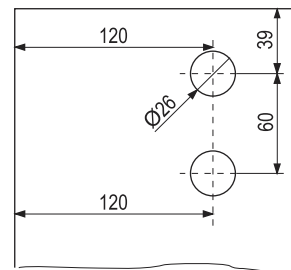

Dimenzije za pripremu (bušenje) stakla



- G - širina vrata (ispune)
- A - širina otvora
- B - preklop vrata u odnosu na otvor
- X - visina svetlog otvora
- L - visina vrata (ispune)
- H - Udaljenost od poda do sredine šine

Venus 22 sistemi za izradu staklenih pregradnih vrata

 40 kg 80 kg	 Staklo 8mm 10mm	 850mm MAX		 Meko zatvaranje
---	---	---	---	---

Određivanje visine ispune i montaža

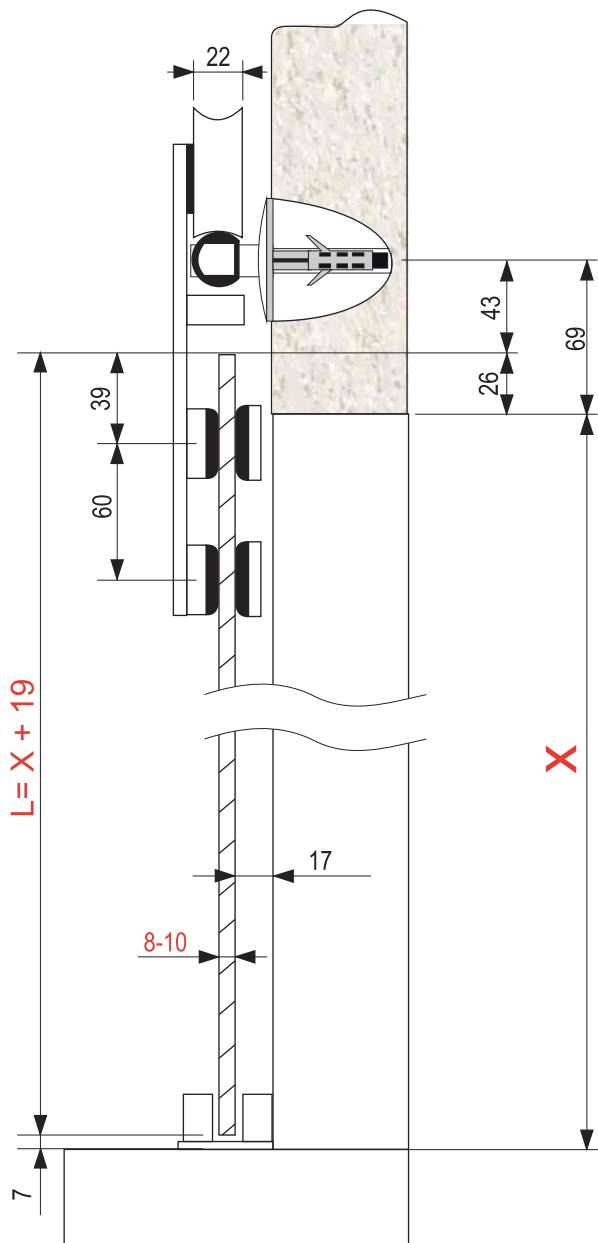

Prikaz pozicioniranja i montaže gornje šine

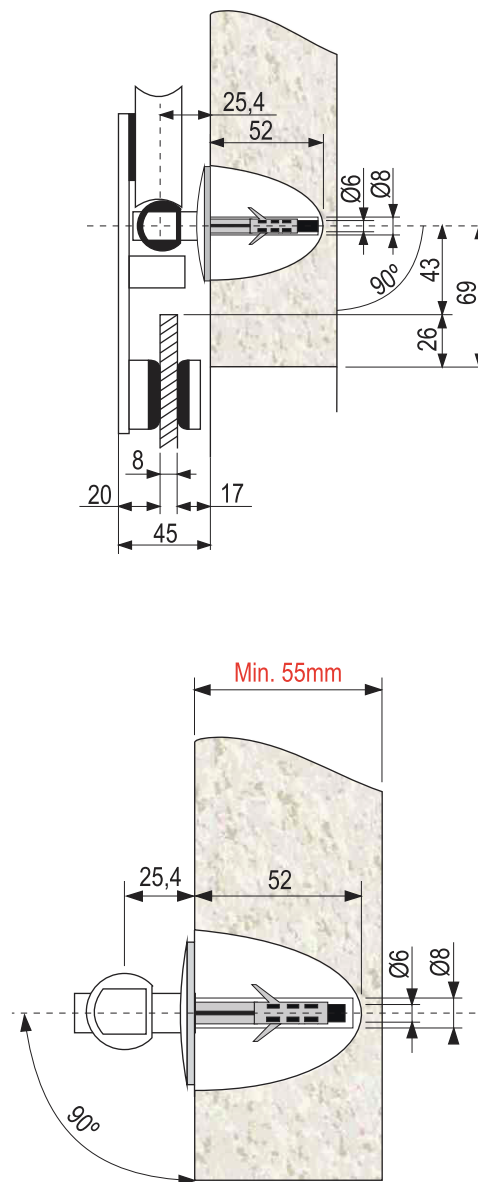

Napomena: Pre montaže proveriti da li je zid na koji se postavlja Venus 22 adekvatne čvrstine i da li odgovara metalnim tiplovima koji se nalaze u setu sa Venus 22 kliznim sistemom.

Venus 22 sistemi za izradu staklenih pregradnih vrata

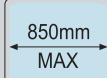
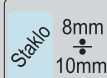

PVS VENUS 22 set 1.67 sa usp.*

Prikaz montaže prihvatnika za usporivač



Prikaz montaže gornje šine na zid

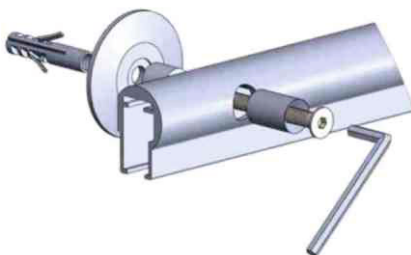

Dimenzije za pripremu (bušenje) stakla

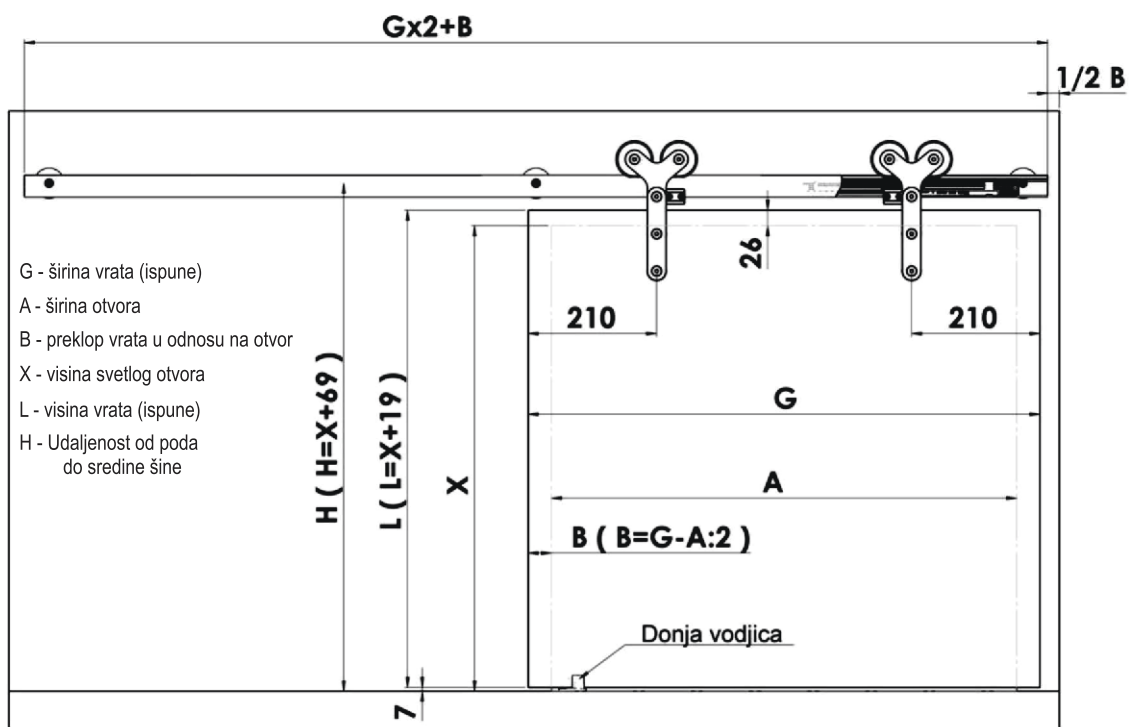
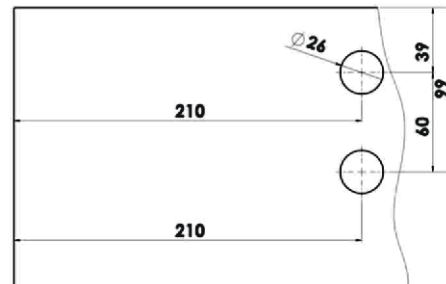

Venus 22 sistemi za izradu staklenih pregradnih vrata

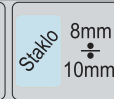

Tehnički crteži i prikaz montaže mehanizma

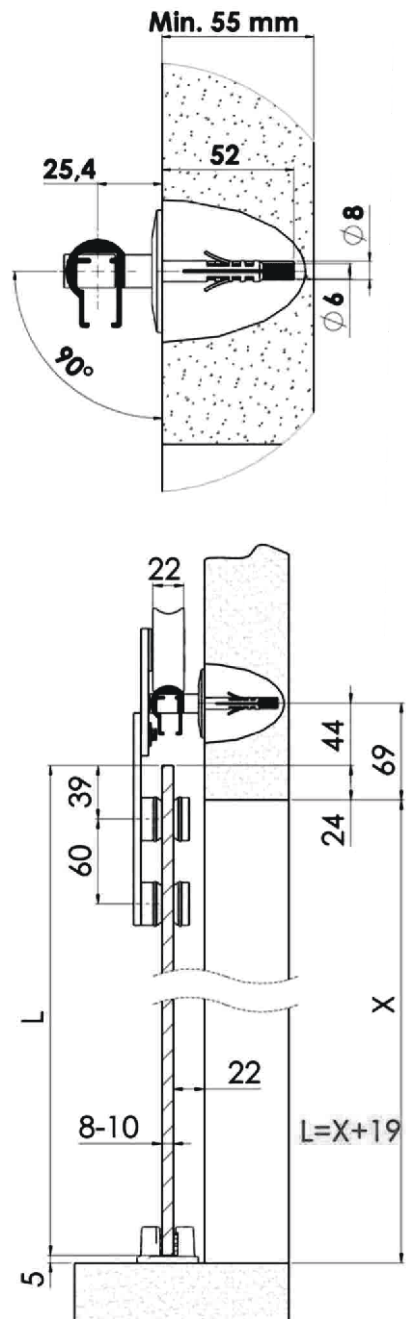

Napomena: Pre montaže proveriti da li je zid na koji se postavlja Venus 22S adekvatne čvrstine i da li odgovara metalnim tiplovima koji se nalaze u setu sa Venus 22S kliznim sistemom.