

SGE G2/3 sistemi za klizna plakarska vrata

SGE-G 2 mehanizam za spoljašnja vrata



art.	j.m.	boja
3607	set	metal

SGE-G 2 mehanizam za unutrašnja vrata



art.	j.m.	boja
3608	set	metal

SGE-G 2/3 usporivači za uska vrata



* Usporivači su namenjeni za vrata od 550 do 650mm širine.

art.	j.m.	boja
8429	set	metal

SGE-G 3 mehanizma za spoljašnja vrata



art.	j.m.	boja
4850	set	metal

SGE-G 3 mehanizma za unutr. vrata LEVA

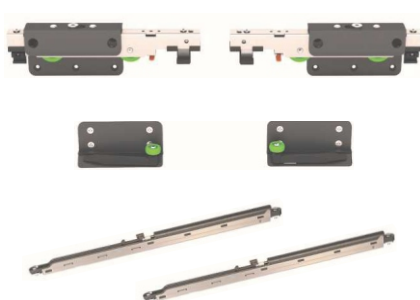

art.	j.m.	boja
4851	set	metal

SGE-G 3 mehanizma za unutr. vrata DESNA



art.	j.m.	boja
4852	set	metal

SGE-G 3 obostrani usporivač za sp. vrata



* Usporivač se uglavnom koristi za spoljašnja vrata na plakarima sa tri klizna krila.

art.	j.m.	boja
4853	kom	metal

SGE-G gornja 2k šina AL

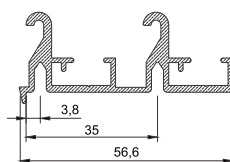

art.	j.m.	boja
3609	m	SM

Prod. dužine (m): 1,5; 2; 2,5; 3; 3,5; 4; 4,5 i 6.

SGE-G donja 2k šina AL

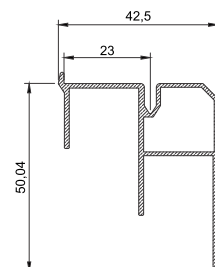

art.	j.m.	boja
3610	m	SM

Prod. dužine (m): 1,5; 2; 2,5; 3; 3,5; 4; 4,5 i 6.

SGE-G maska gornjeg meh za sp. vrata

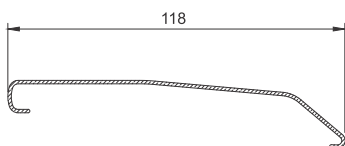

art.	j.m.	boja
3611	m	SM

Prod. dužine (m): 1,5; 2; 2,5; 3; 3,5; 4; 4,5 i 6.

SGE-G donja/gornja vodica AL

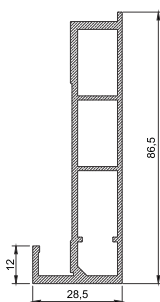

art.	j.m.	boja
4181	m	SM

Prod. dužine (m): 1,5; 2; 2,5; 3; 3,5; 4; 4,5 i 6.

SGE-G rukohvati AL

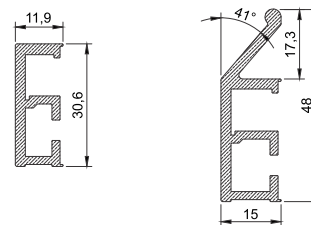

art.	art.
4180	7683
j.m.	j.m.
m	m
boja	boja
SM	SM

Prod. dužine (m): 3,0 ; 6,0.

SGE G2/3 sistemi za klizna plakarska vrata

SGE-G vezni profil AL

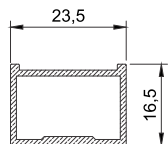

art.	j.m.	boja
4185	m	SM
Prod. dužine (m): 1,5; 2; 2,5; 3; 3,5; 4; 4,5 i 6.		

SGE-G pregradni profil AL

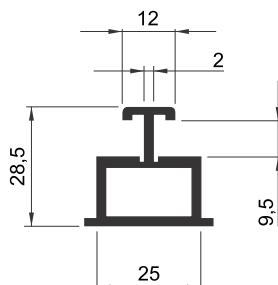

art.	j.m.	boja
4184	m	SM
Prod. dužine (m): 1,5; 2; 2,5; 3; 3,5; 4; 4,5 i 6.		

SGE-G vezni mehanizam za AL ram

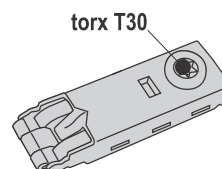

art.
4187
j.m.
kom
boja
metal

SGE-G PVC ispuna za staklo



art.
5717
j.m.
m
boja
transp.

*Dužina profila je 3,5m

Preporučeni zatezači (španeri) za drvena vrata

ZAT španer za vrata XT



art.	j.m.	boja
3639	kom	metal

ZAT španer za vrata sa PVC kapom MT



art.	j.m.	boja
1503	kom	metal

ZAT španer za vrata ZT



art.	j.m.	boja
48	kom	metal

ZAT TS 211 španer/profil za vrata do 20mm

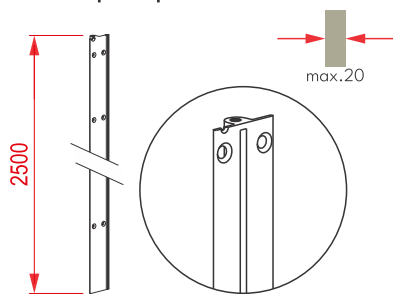

art.	j.m.	boja
4490	par	metal

ZAT TS 321 španer/profil za vrata od 20mm

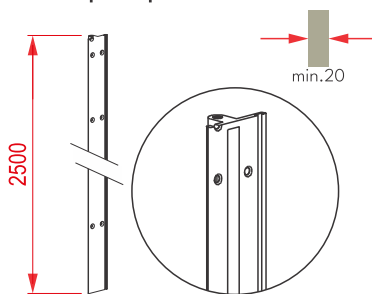

art.	j.m.	boja
4489	par	metal

ZAT TS 592 zatezač 203-220cm

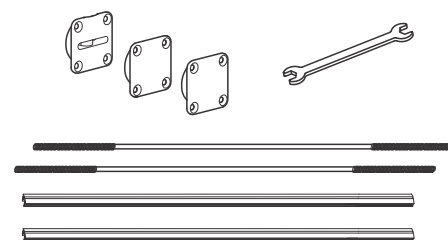

art.	j.m.	boja
4062	par	metal

ZAT TS 595 zatezač 204-224cm

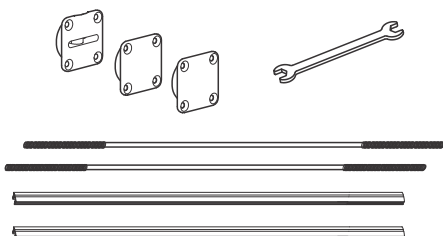

art.	j.m.	boja
3697	par	metal

ZAT TS 594 zatezač 220-245cm

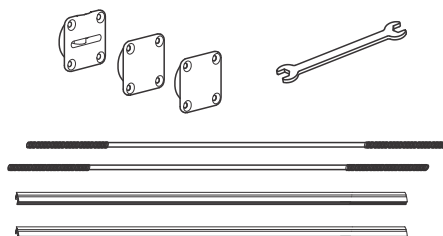

art.	j.m.	boja
4063	par	metal

ZAT TS 596 zatezač 245-260cm

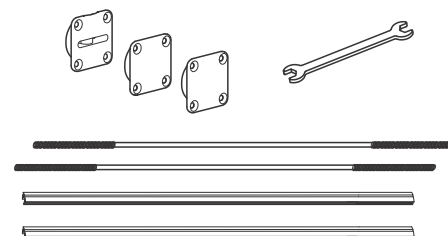

art.	j.m.	boja
4064	par	metal

SGE G2/3 sistemi za klizna plakarska vrata

Tehnički detalji i planiranje

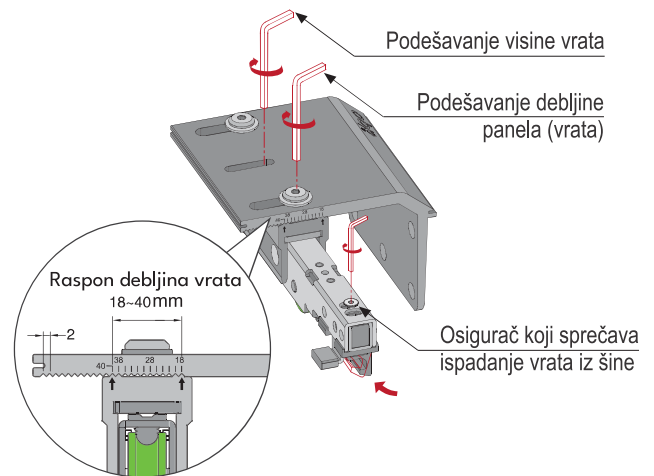
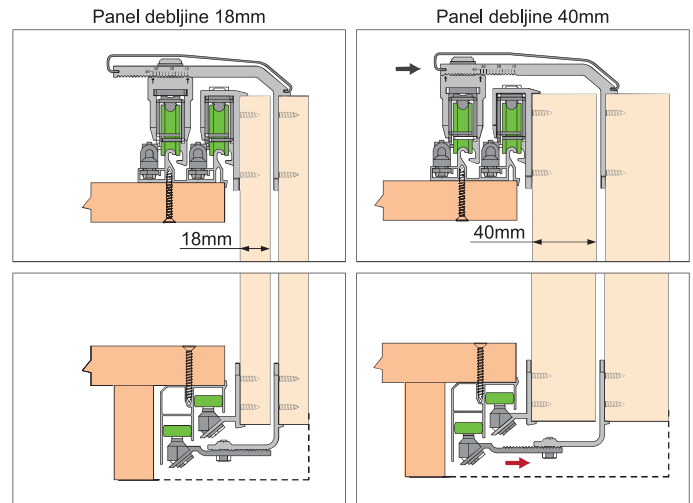
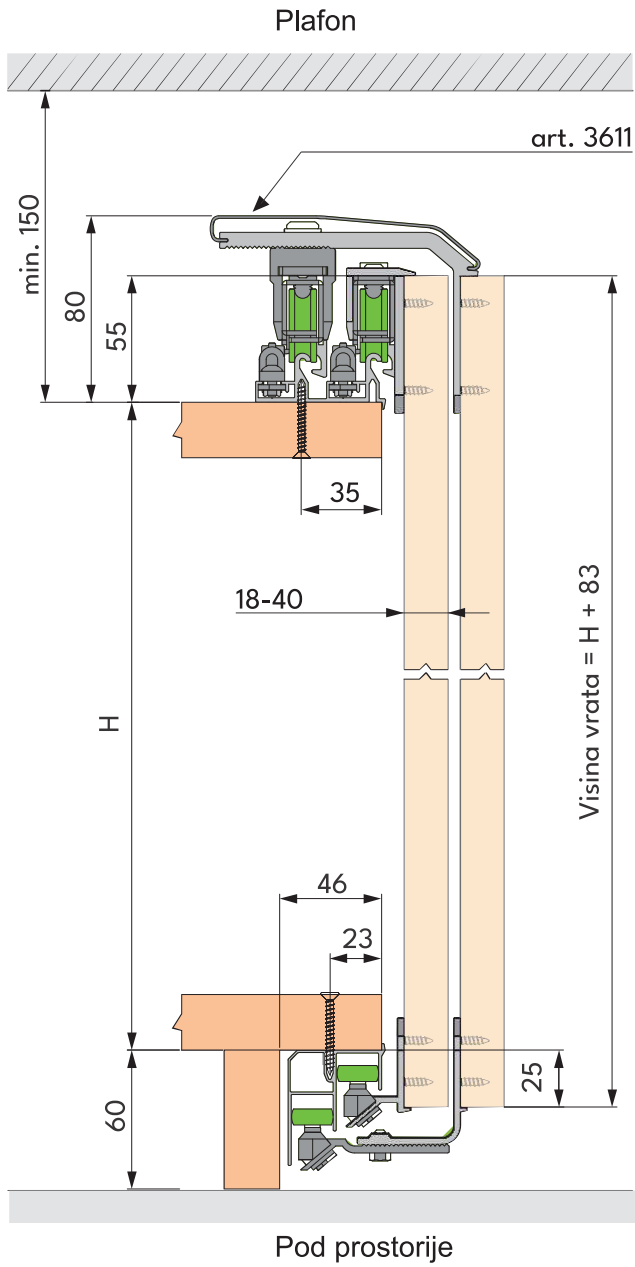

SGE G2/3 sistemi za klizna plakarska vrata

Tehnički detalji i planiranje

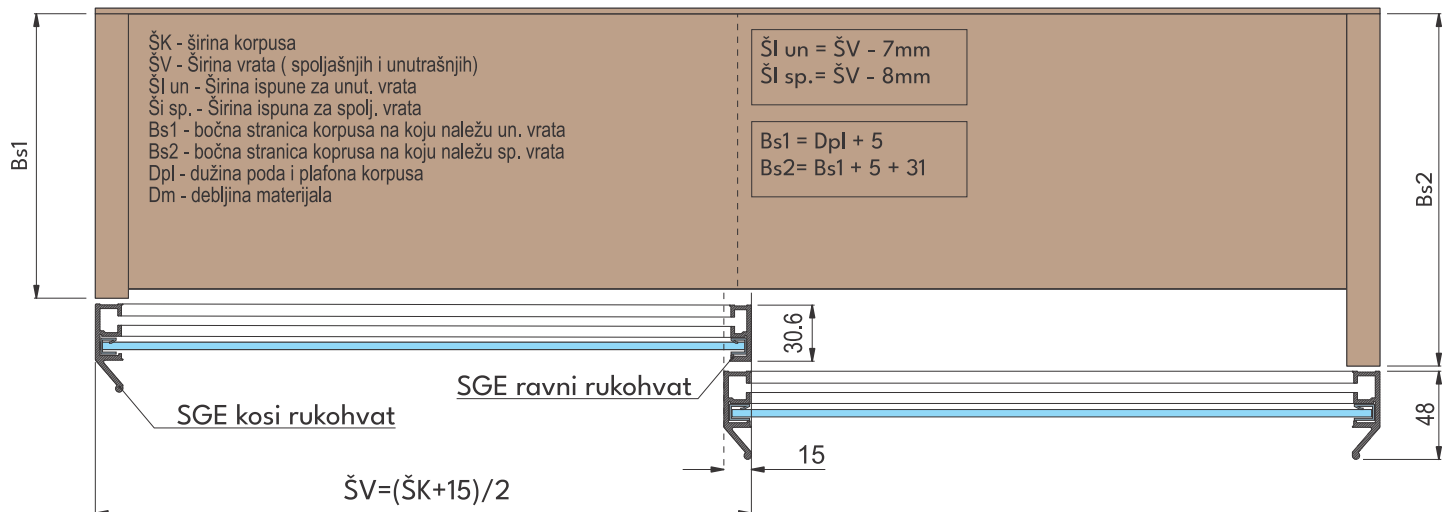
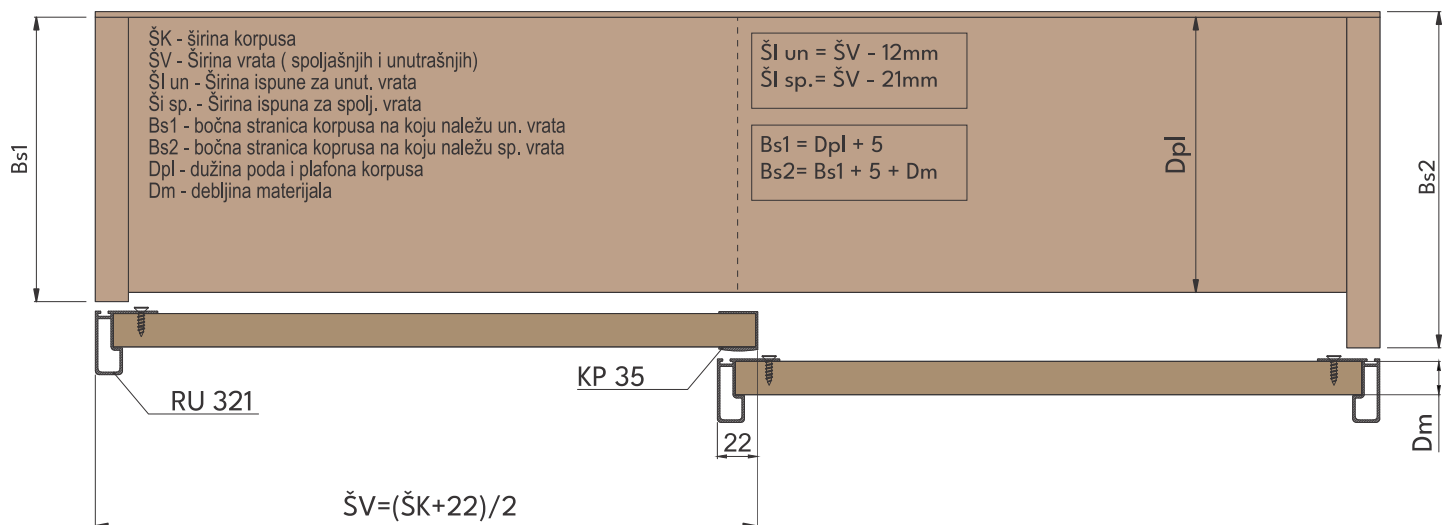
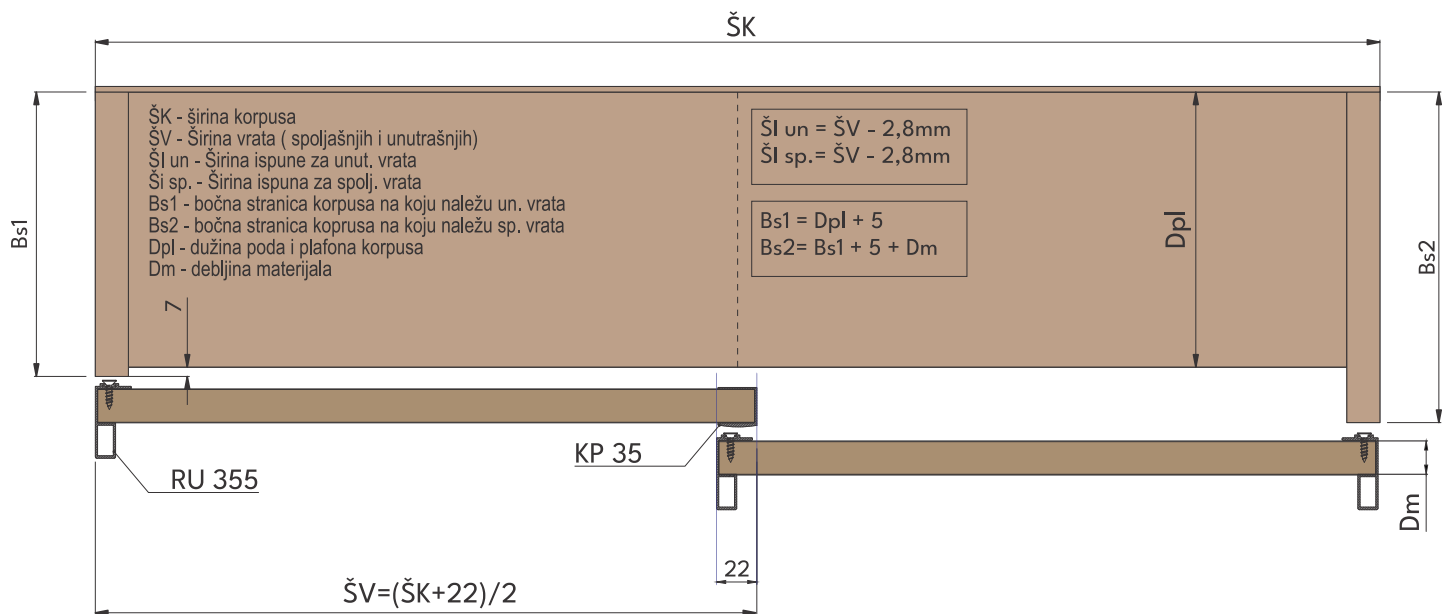

SGE G2/3 sistemi za klizna plakarska vrata

Tehnički detalji i planiranje

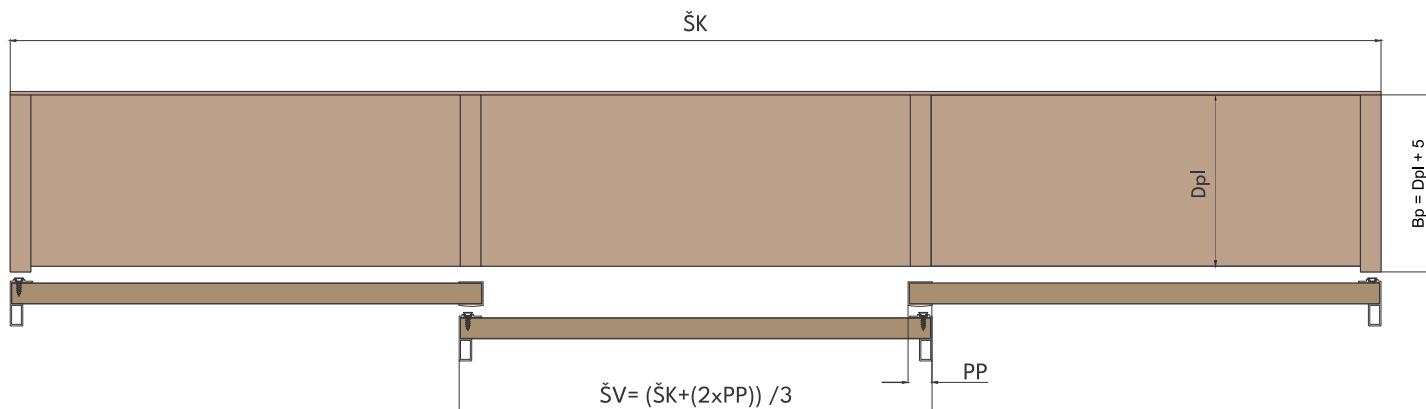

$\mathring{S}K$ - širina korpusa

$\mathring{S}V$ - širina vrata

PP - preklop

Dpl - Dužina poda i plafona korpusa

Bp - Bočna stranica korpusa

Tabela preklopa u zavisnosti od rukohvata

	RU 355	RU 321	SGE Al kosi i ravni ruk.
PP	22	22	15

Napomena: U situacijama kada se na klizna vrata ne postavljaju nikakvi rukohvati, uzeti u obzir da je preklop (PP) 10mm. Ovo važi za plakare sa dva i tri klizna krila. Preporuka je da se ovaj tip vrata ne izrađuje bez španera (zatezača).

Prikaz prostora koji zauzimaju rukohvati kada su vrata otvorena:

Zadatih 10mm izmedju rukohvata je preporučen prostor koji je potreban za otvaranje vrata, ali taj prostor može biti veći ili manji

RU 355 rukohvati + KP 35 ukrutni profil

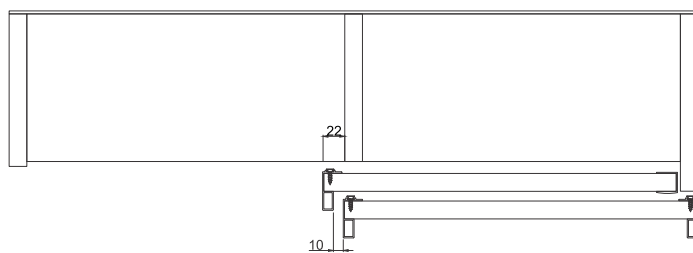
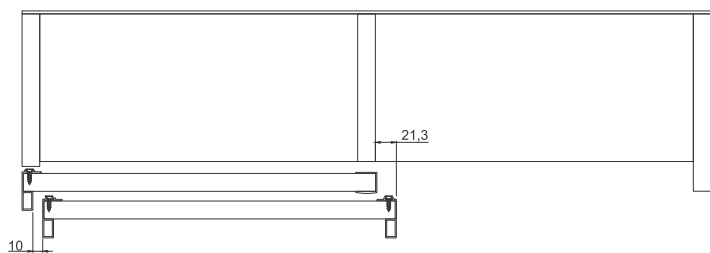

RU 321 rukohvati + KP 35 ukrutni profil

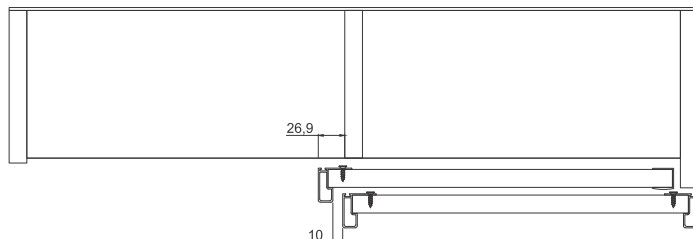
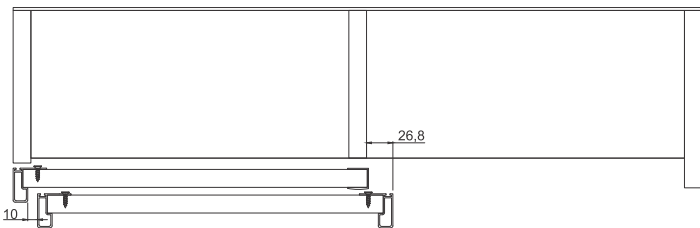

SGE G ravni i kosi rukohvati

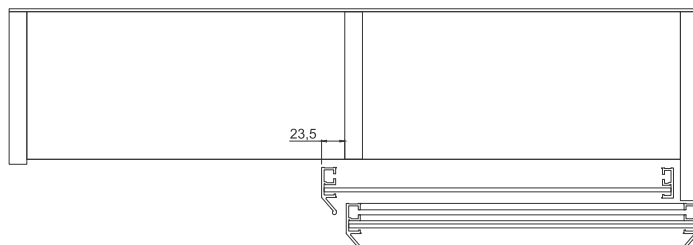
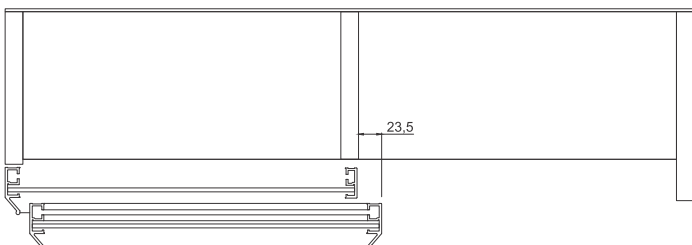

SGE G2/3 sistemi za klizna plakarska vrata

Tehnički detalji i dimenzije za staklena vrata u SGE G Al ramu

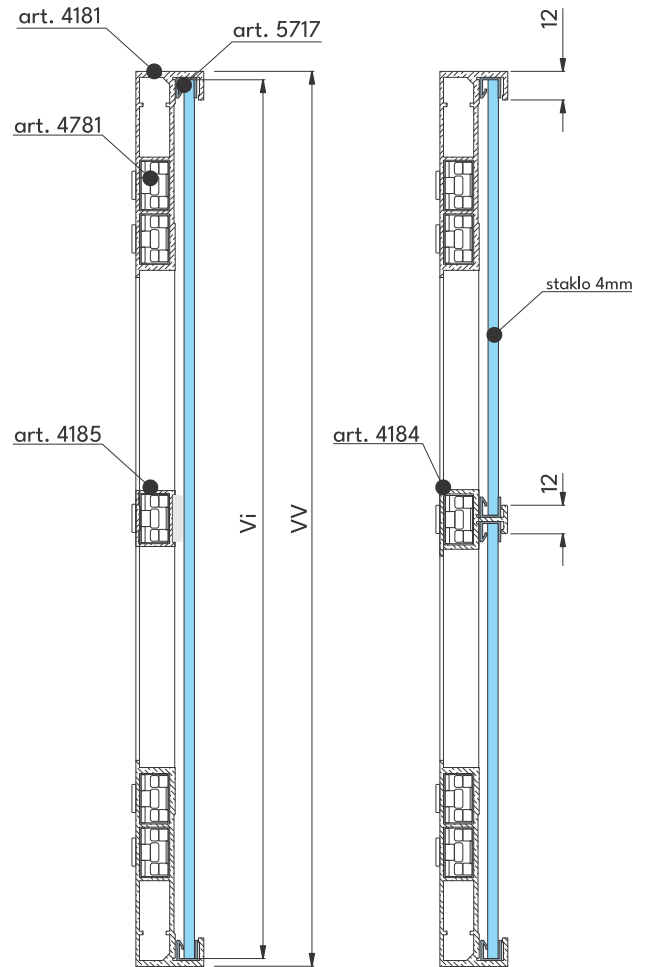
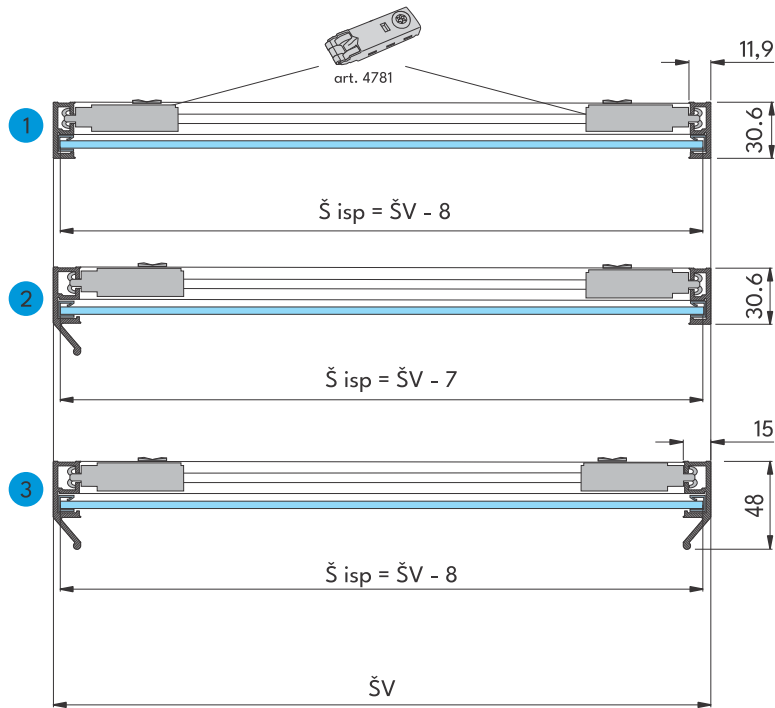

$V_i = V_v - 8\text{mm}$

*Ukoliko se postavlja «H» pregradni profil potrebno je oduzeti dodatna 3mm po jednom pregradnom profilu.

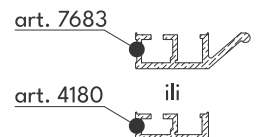

Priprema profila za vezne elemente

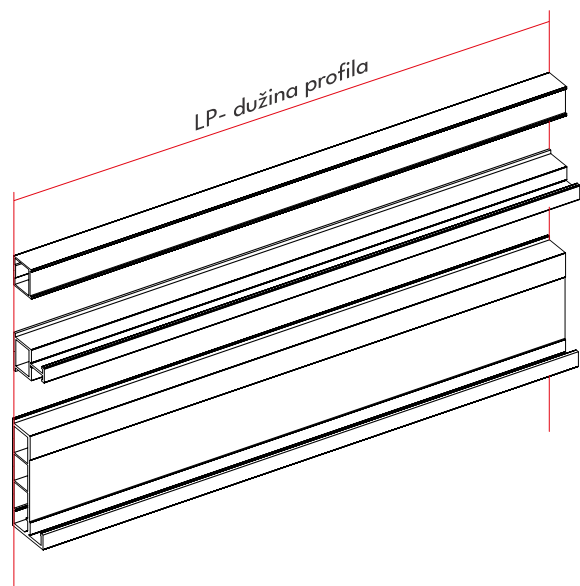
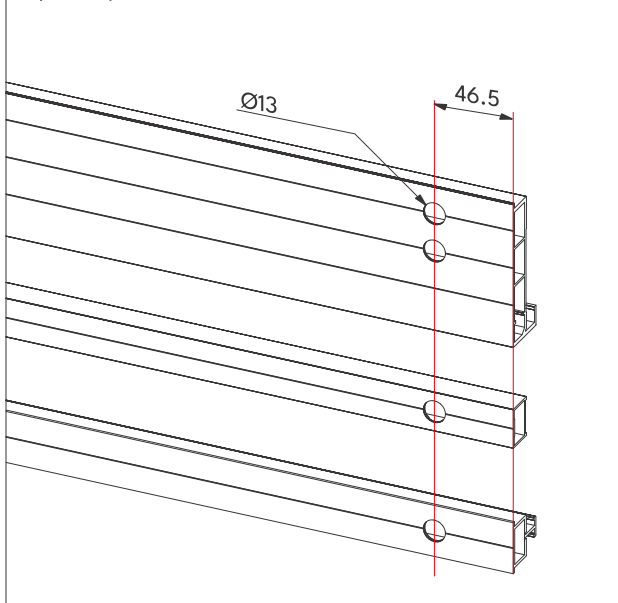

	1	2	3
LP	ŠV-23	ŠV-26	ŠV-29

SGE G2/3 sistemi za klizna plakarska vrata

Tehnički detalji i planiranje

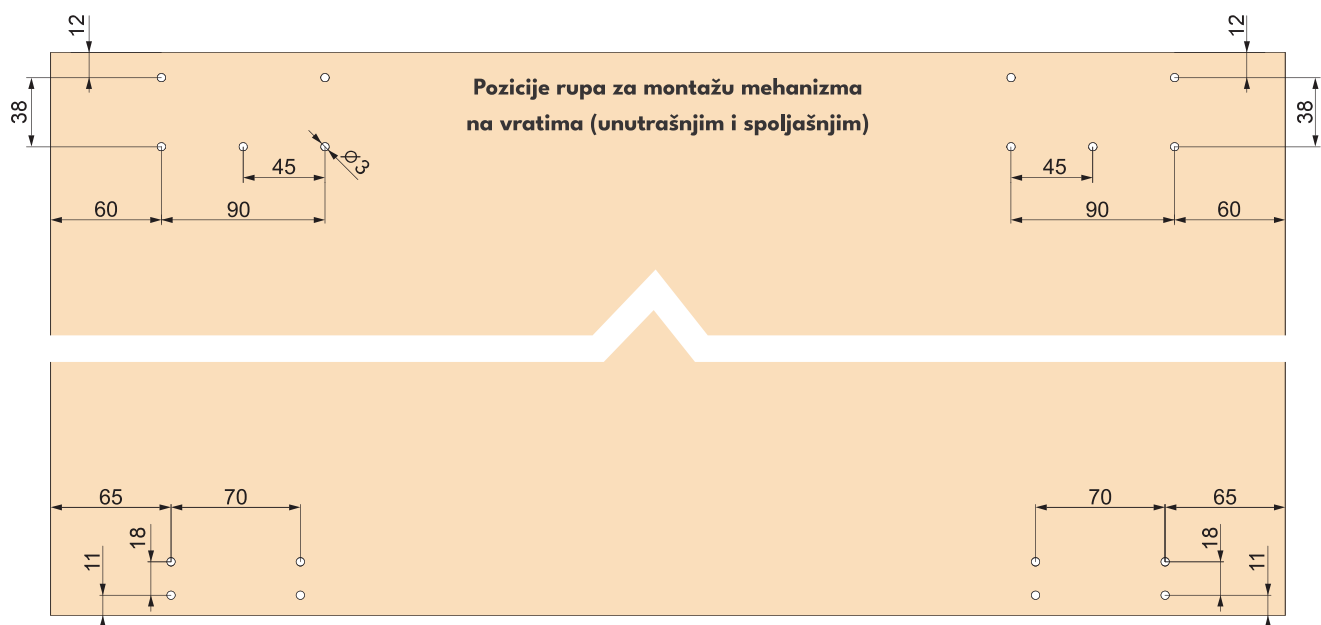

Prikaz montaže mehanizama na spoljašnja vrata

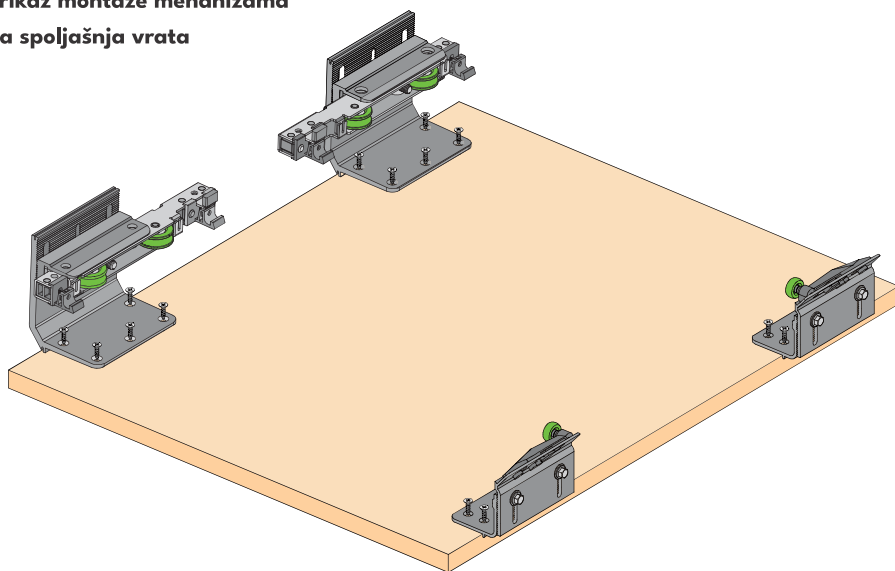

Prikaz montaže mehanizama na unutrašnja vrata

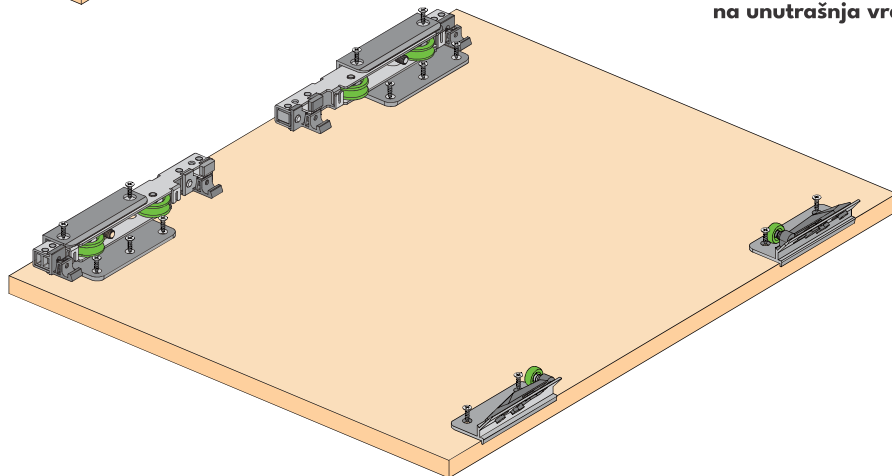

SGE G2/3 sistemi za klizna plakarska vrata

Montaža šina i vrata na koprus plakara

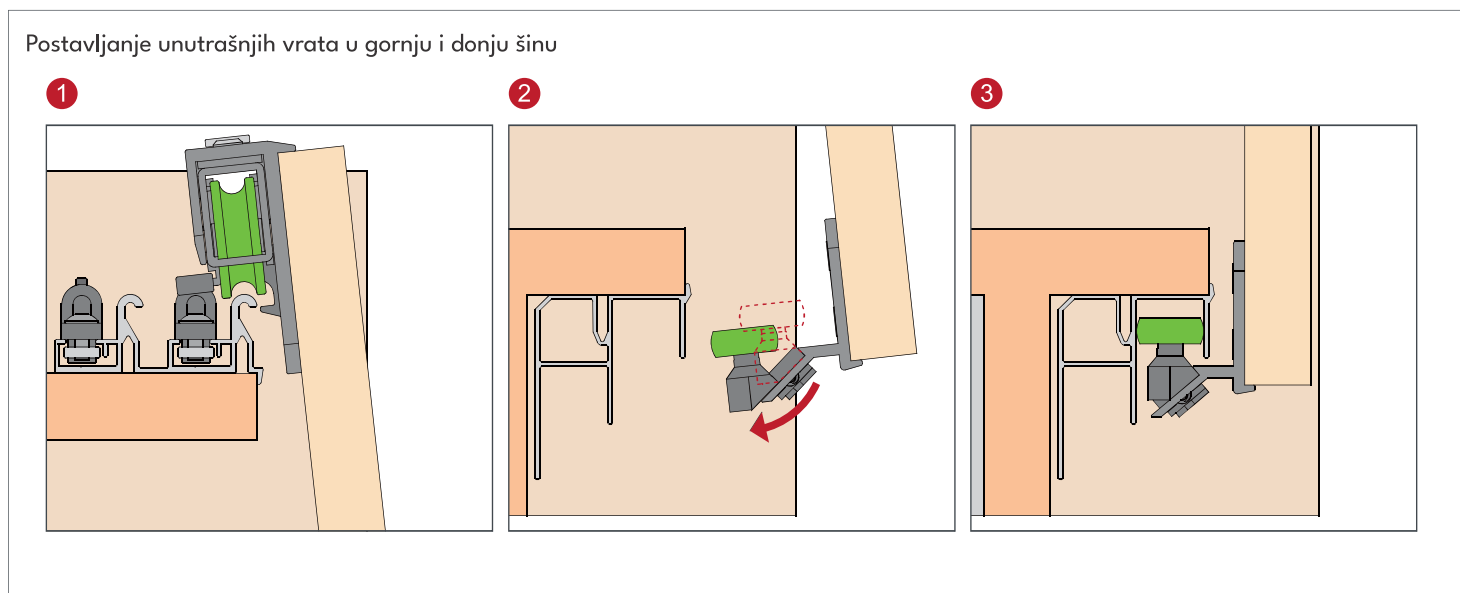
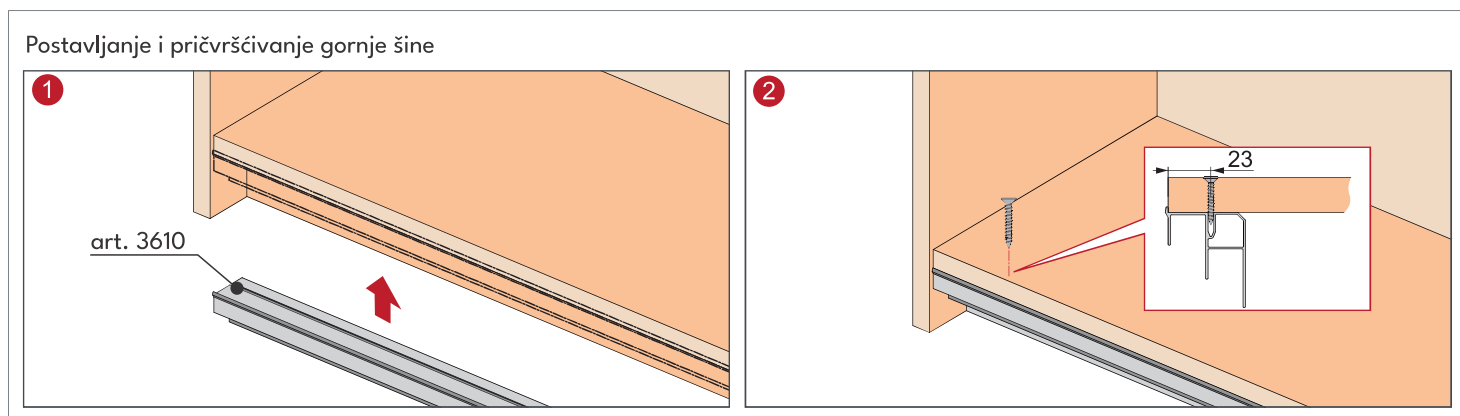
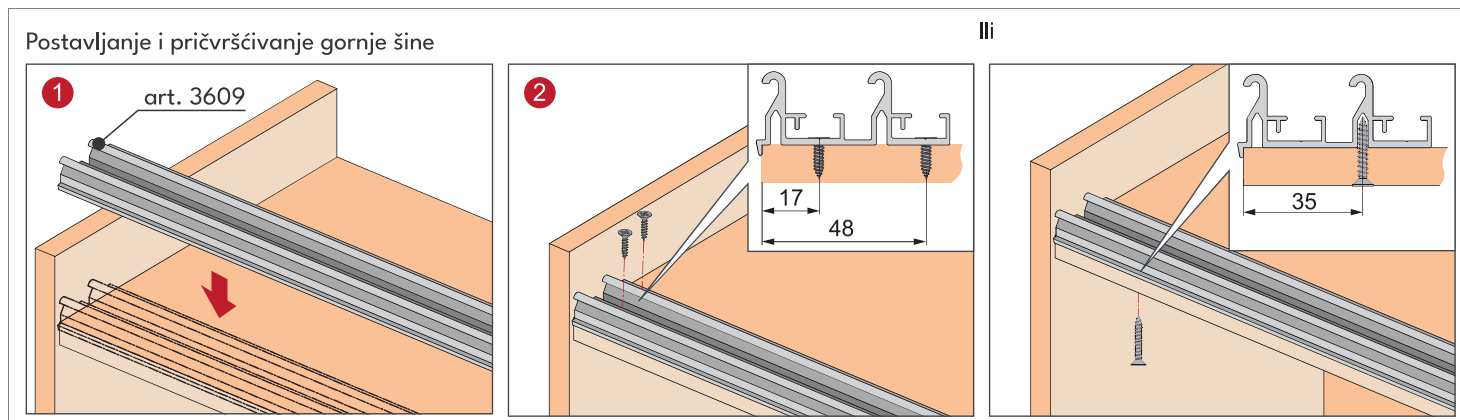

SGE G2/3 sistemi za klizna plakarska vrata

Montaža šina i vrata na koprus plakara

Postavljanje i podešavanje spoljašnjih vrata

1 Osloboditi mehanizam za podešavanje

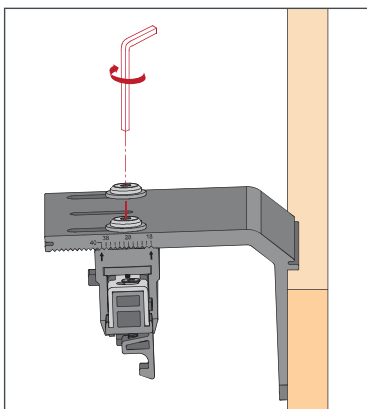

2 Podesiti gornju «šapu» shodno debljini vrata

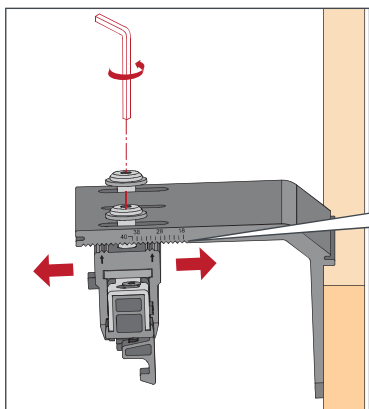

* Primer: debljina panela (vrata):40mm

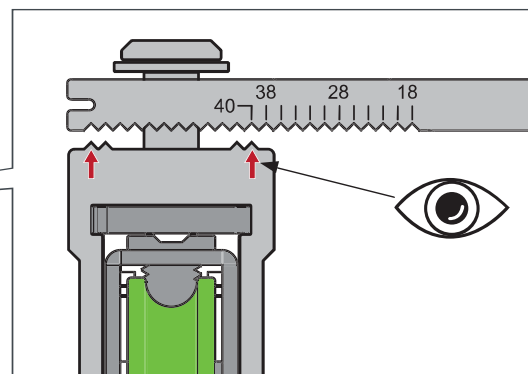

3 Osloboditi mehanizam za podešavanje

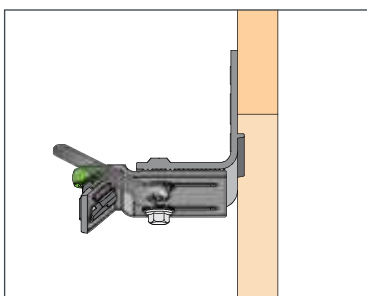

4 Podesiti donju «šapu» shodno debljini vrata

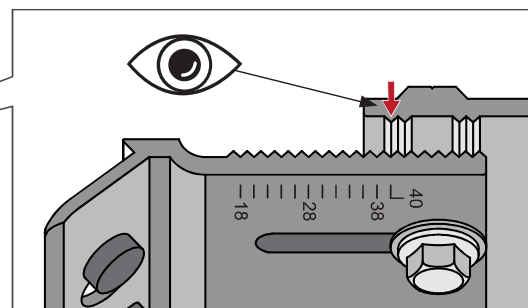
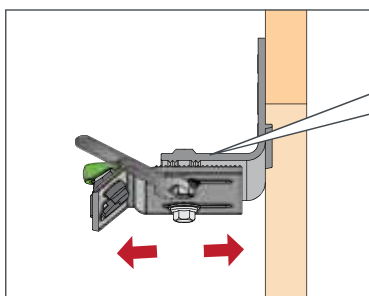

5

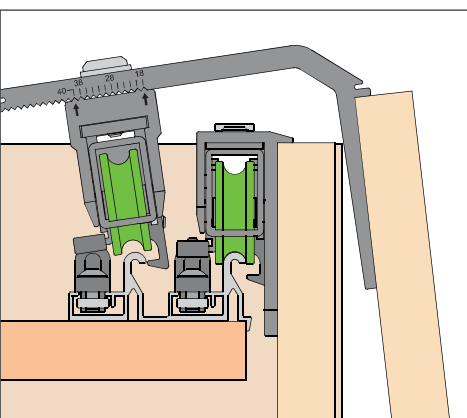

6

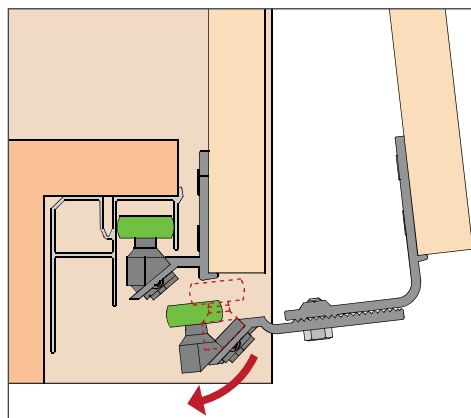

7

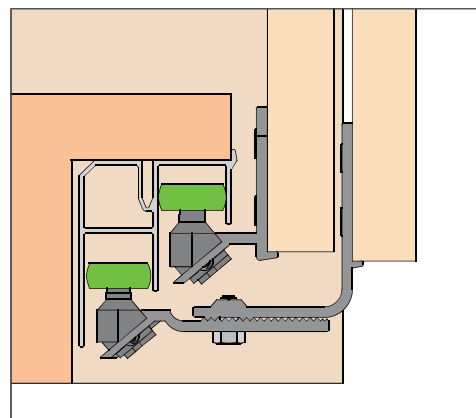

* Ukoliko montirate vrata koja smo mi izradili, mehanizmi će biti predhodno podešeni shodno debljini materijala.
Odonosi se isključivo na staklena vrata u aluminijumskom ramu.

SGE G2/3 sistemi za klizna plakarska vrata

Montaža šina i vrata na koprus plakara

Visinsko podešavanje vrata

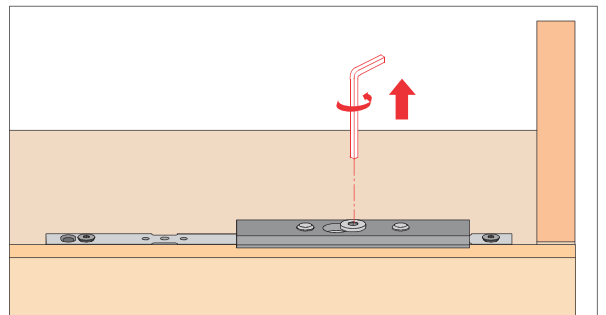
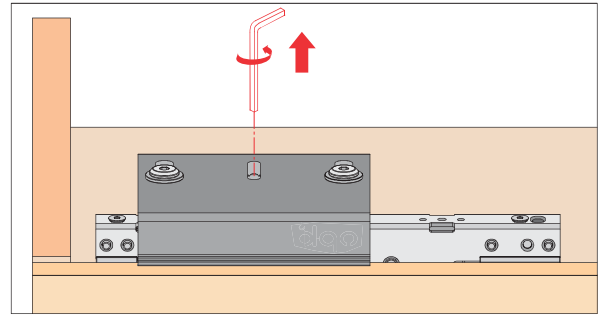
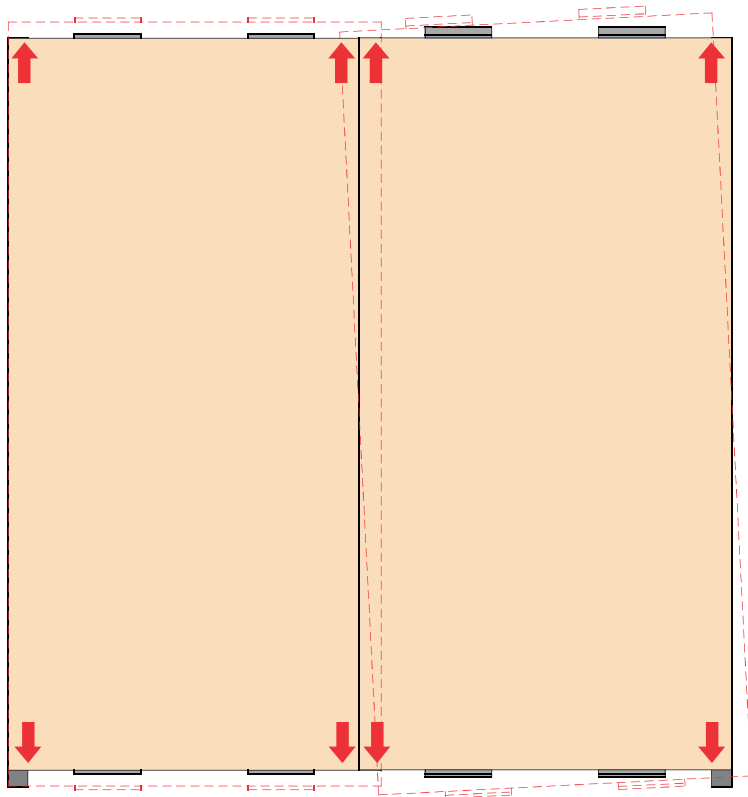

Montaža usporivača za vrata

1 Napregnuti prihvatnik na usporivaču

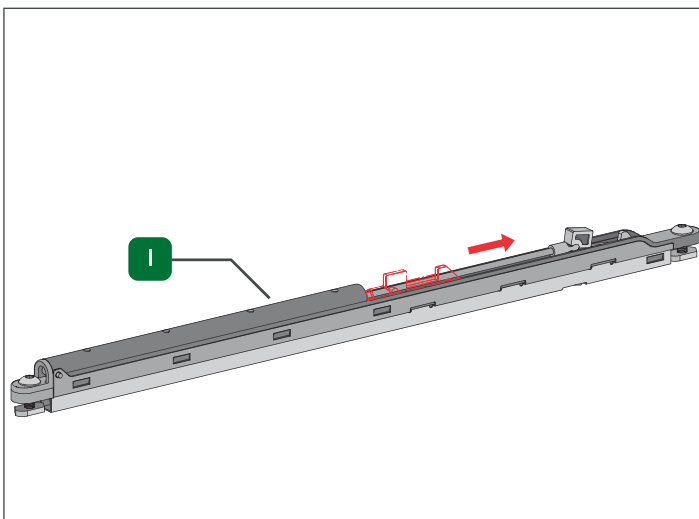

2*

* Ovaj način ubacivanja usporivača odozgo u gornju šinu je moguće uraditi samo kada su u pitanju OPK Europe mehanizmi, kada su u pitanju klasični OPK mehanizmi potrebno je ubaciti usporivače u gornju šinu pre montaže iste na plafon korpusa.

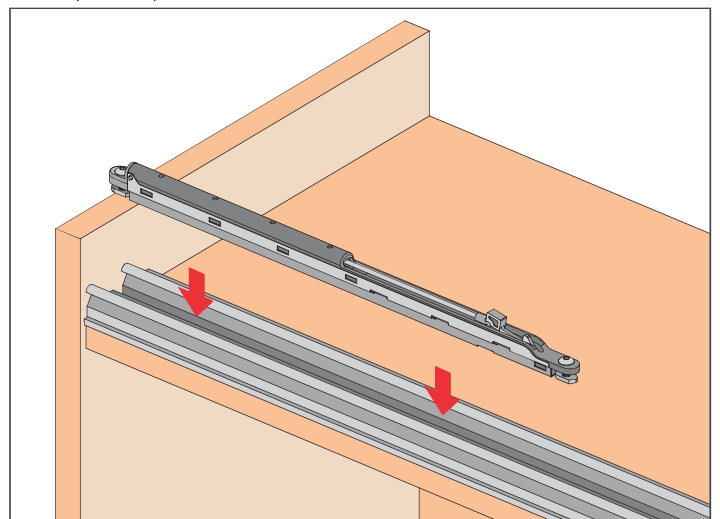

Prikaz pravilnog pozicioniranja usporivača u gornju šinu

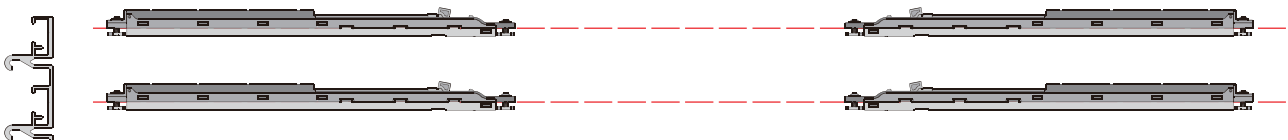

SGE G2/3 sistemi za klizna plakarska vrata

Montaža šina i vrata na koprus plakara

Pozicioniranje dvosmernog usporivača

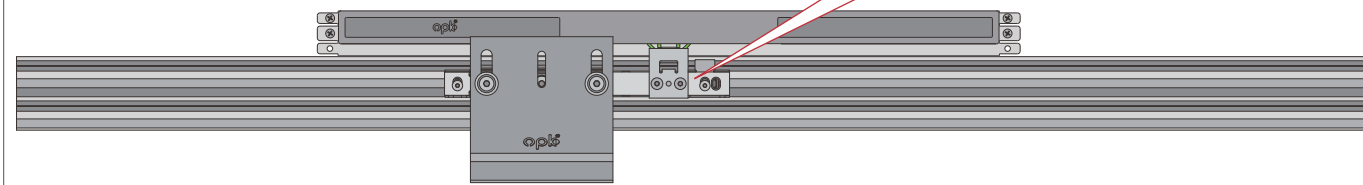
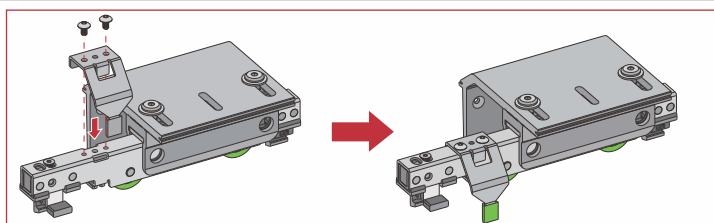

Pozicija dvosmernog usporivača na plafonu korpusa

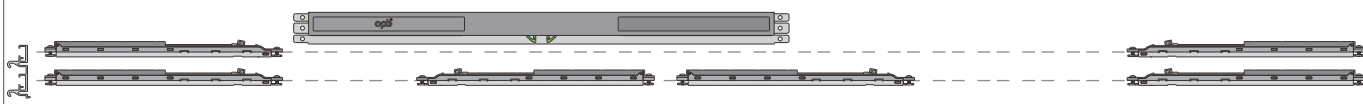

Pozicija prihvanika za usporivač

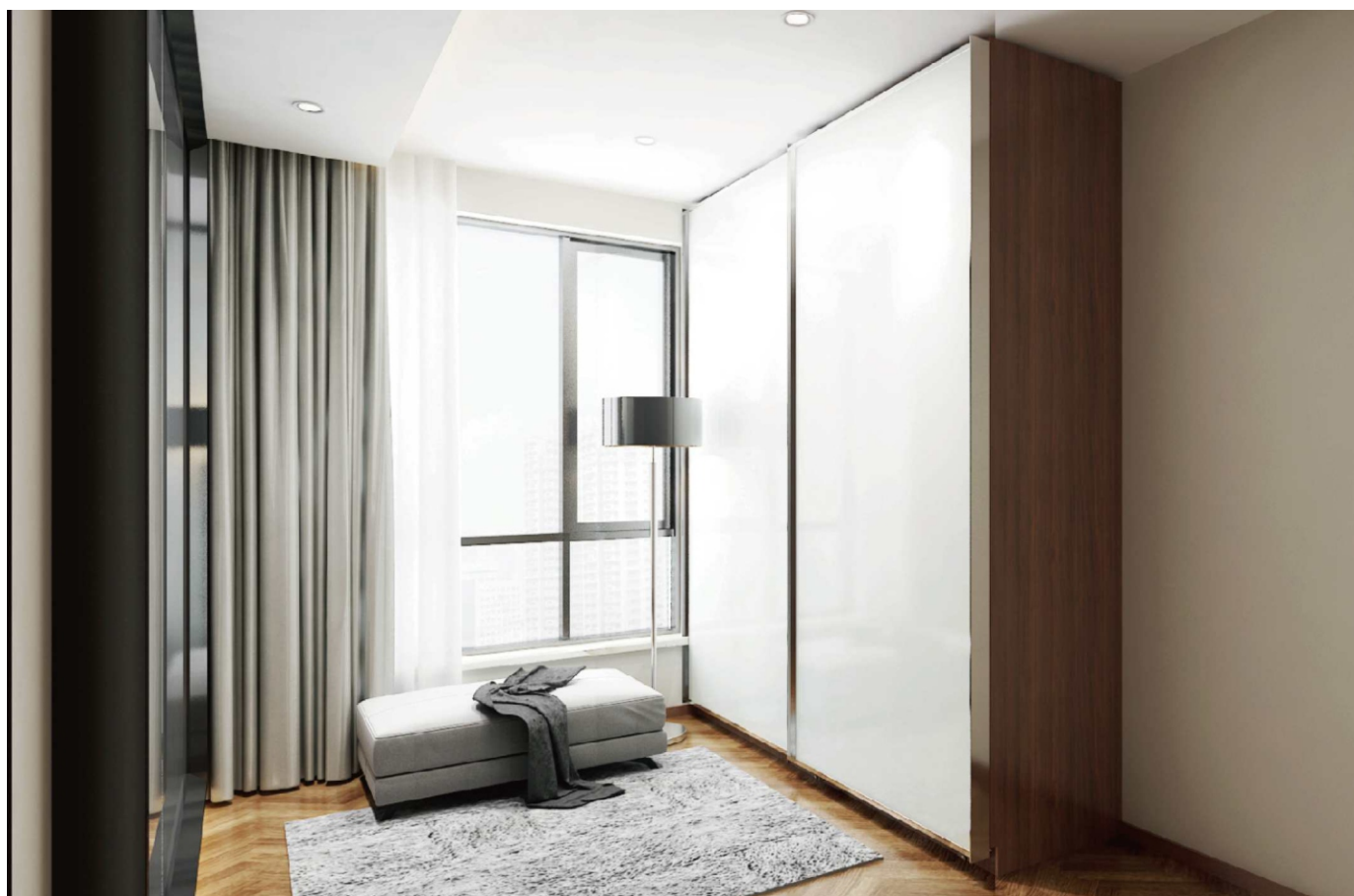
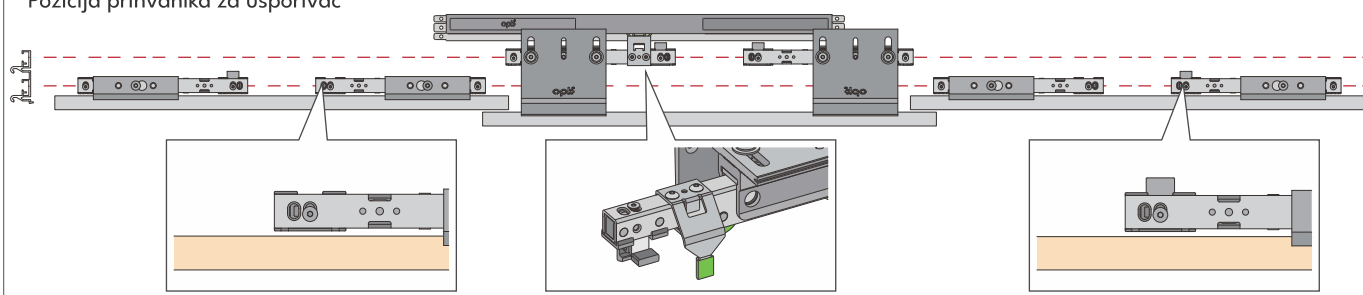

SGE G2/3 sistemi za klizna plakarska vrata

Montaža šina i vrata na koprus plakara

Nakon natezanja prihvatnika u usporivaču, potrebno je da ubacite gornji mehanizam u usporivač i pozicionirate vrata u krajnji položaj. Zategnuti dva inbus vijka na usporivačima u željenom položaju i povucite vrata tako da mehanizam izađe iz usporivača.

