

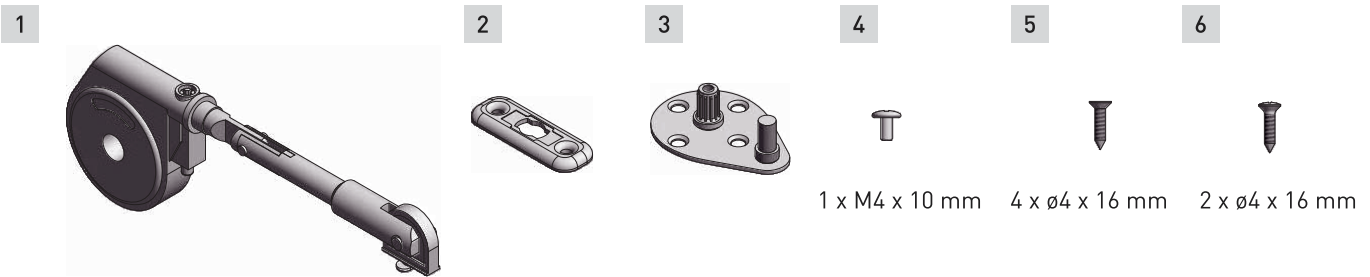

Karakteristike:



Set uključuje:



1. amortizer
2. prednji konektor
3. montaža na telo
4. montažni vijak 1xM4x10mm
5. montažni vijak 4xØ4x16mm
6. montažni vijak 2xØ4x16mm

	Približna visina prednjeg dela:
OZ bife mehanizam VIM P1 MF - šifra: 5058	250 - 340 mm
OZ bife mehanizam VIM P2 MF - šifra: 5059	350 - 400 mm

Planiranje:

Razmak između montažnih rupa:

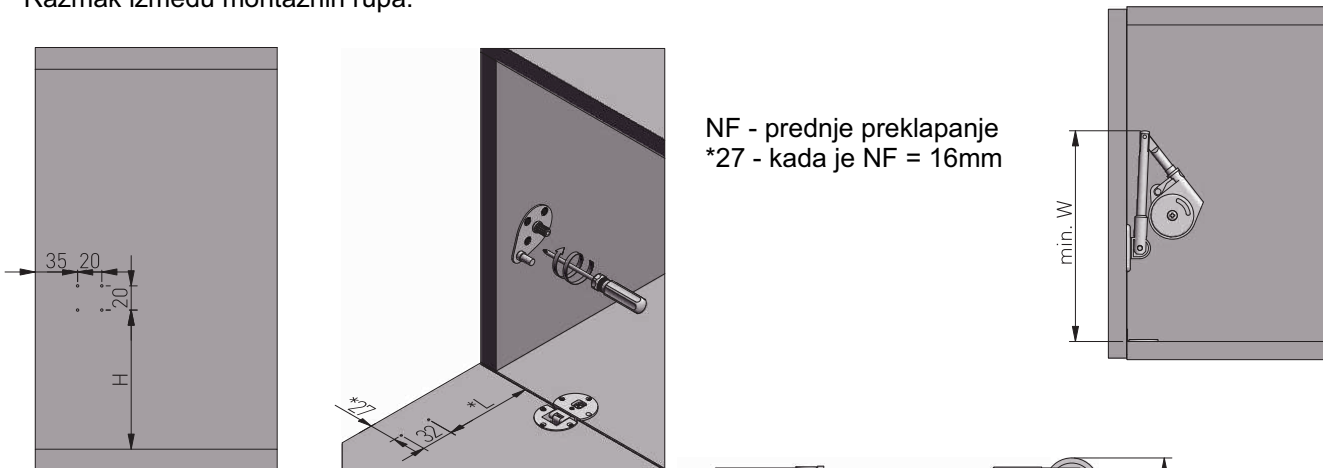

Izbor mehanizma:			
Mehanizam:	H (mm)	L (mm)	min. W (mm)
P1	63	58	140
P2	115	89	210

Dužine:	
Mehanizam:	L (mm)
P1	165
P2	220

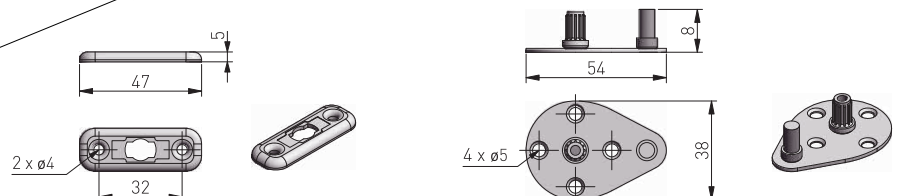

Maksimalna težina u odnosu na visinu krila:

P1

Visina:	Širina (mm):			
	600 mm	700 mm	800 mm	900 mm
	Broj mehanizama:			
250 mm	1	1	2	2
260 mm				
270 mm				
280 mm				
290 mm				
300 mm				
310 mm	2			
320 mm				
330 mm				
340 mm				

P2

Visina:	Širina (mm):			
	600 mm	700 mm	800 mm	900 mm
	Broj mehanizama:			
350 mm	1	2	2	2
360 mm				
370 mm				
380 mm				
390 mm				
400 mm				

Montaža:

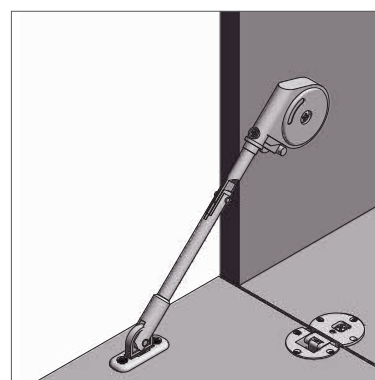
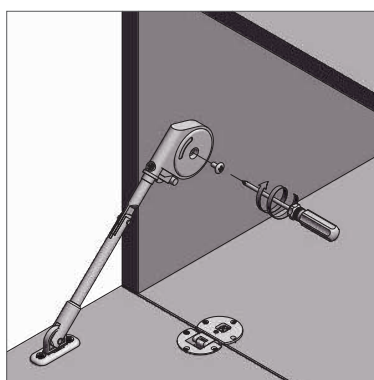
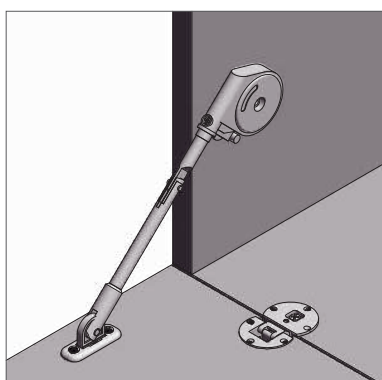
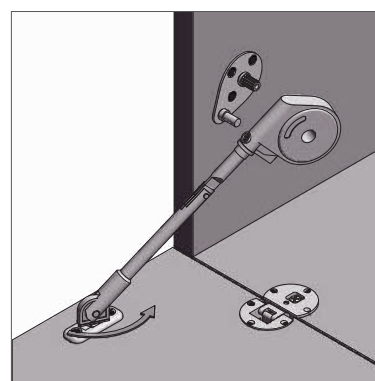
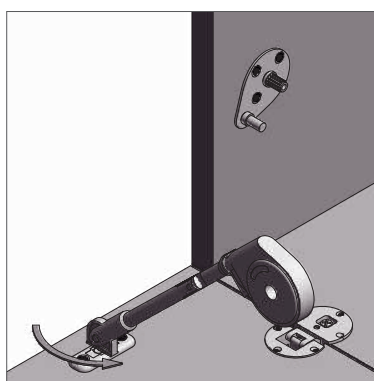
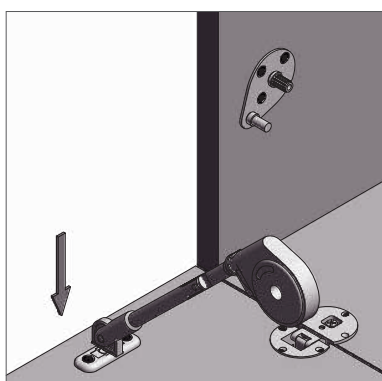
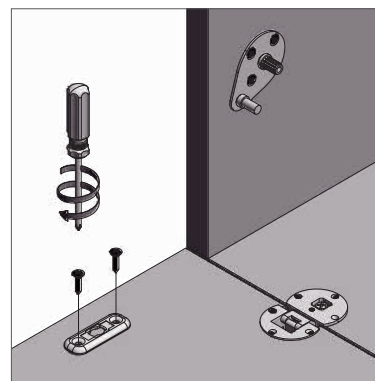
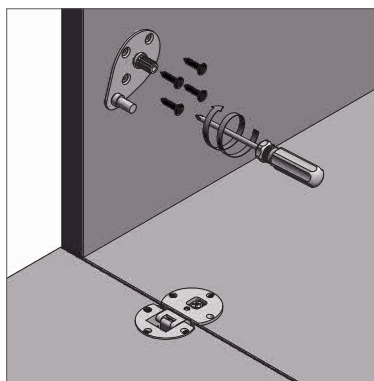
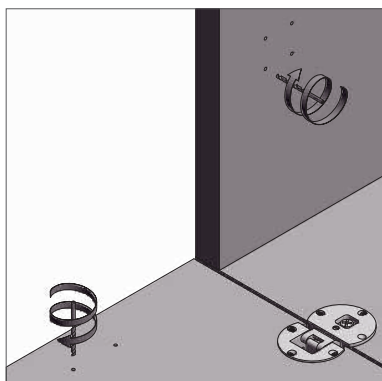

Podesivi ugao zaustavljanja:

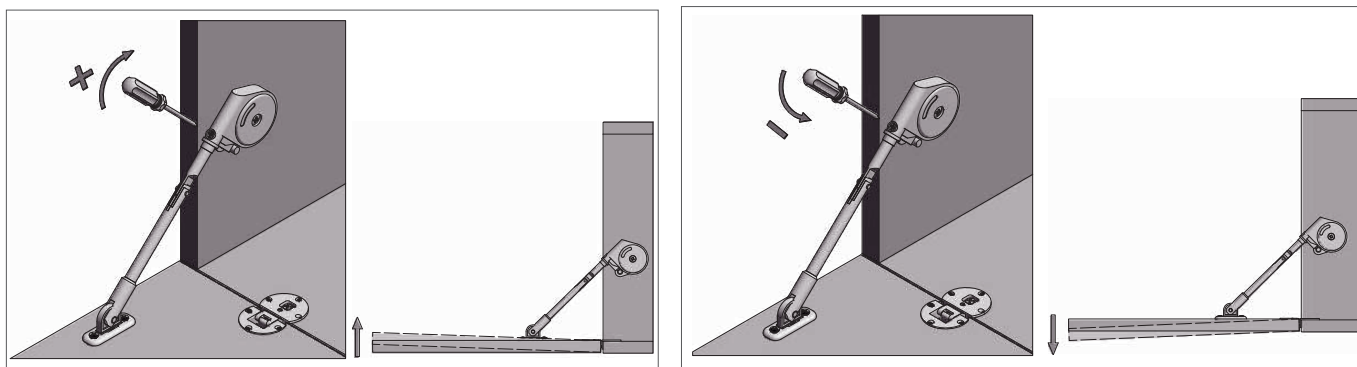

Demontaža:

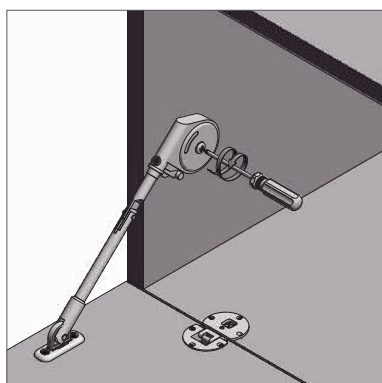

P1

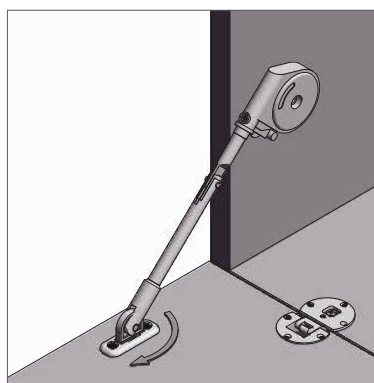

P2

