

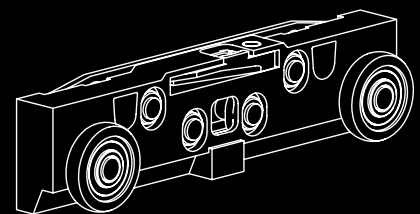

**Magic**  
staklena pregradna vrata

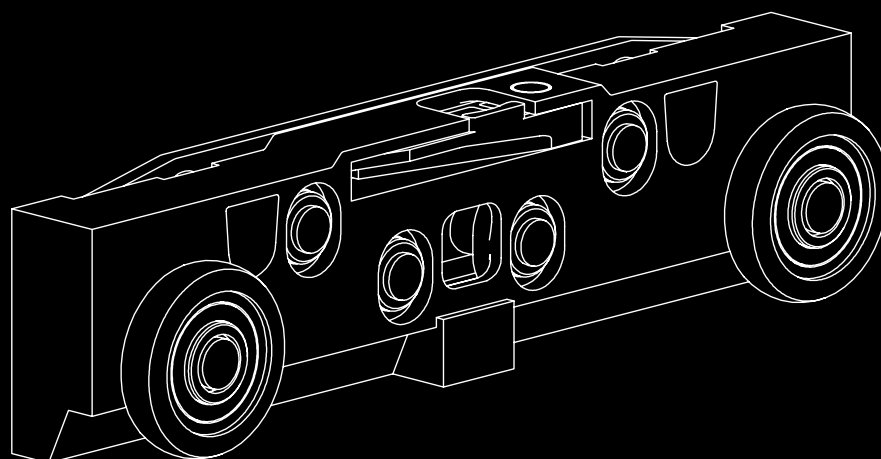



## Magic Staklo

Nevidljivi klizni sistem za pregradna vrata  
Sistema invisibile di scorrevoli per porte

PATENTIRANI

Arhitektonski klizni sistem za izradu staklenih vrata pregradnog zida sa usporivačima.

# Šema vrata sa nitnama

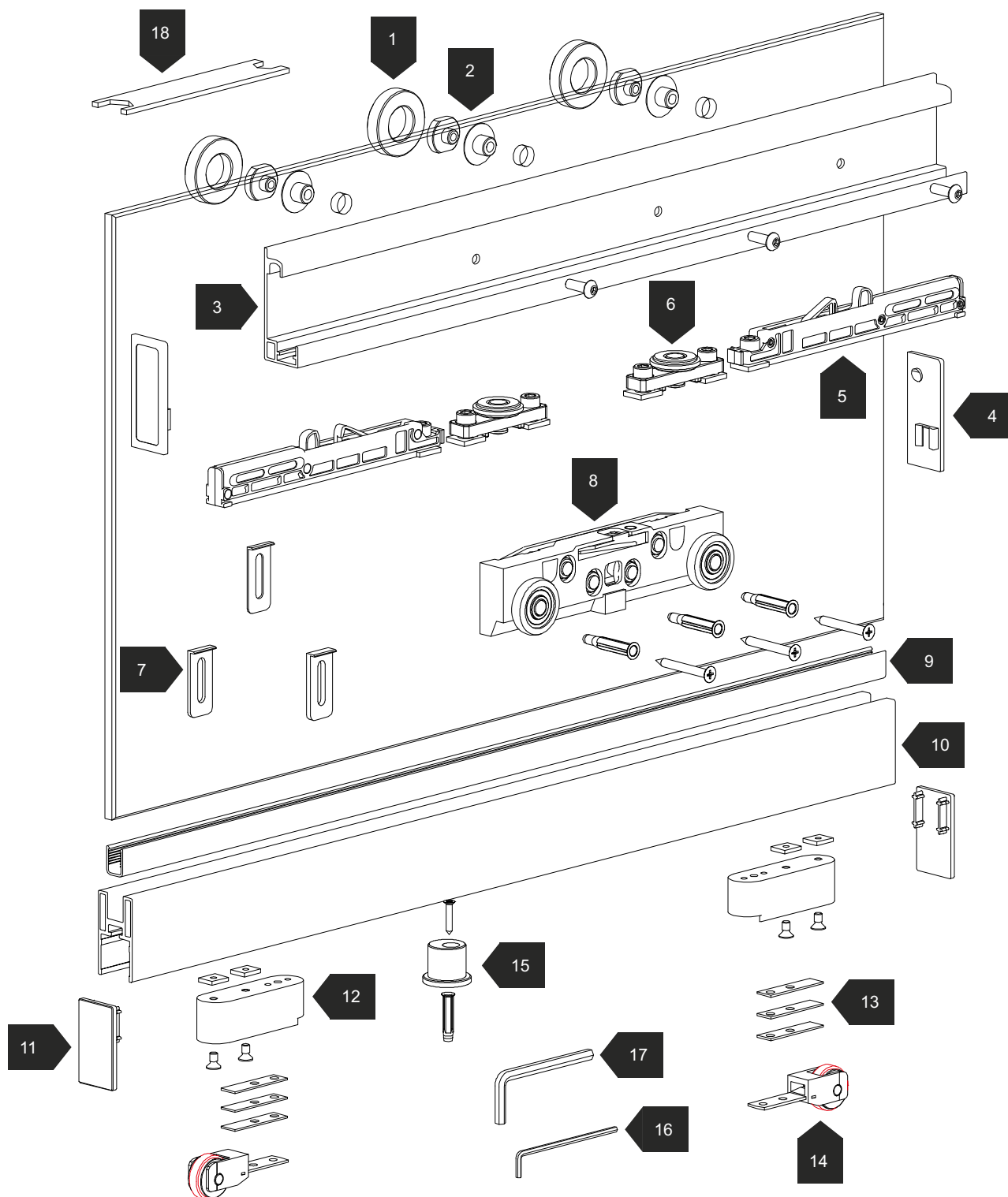









800 mm ÷ 1100 mm





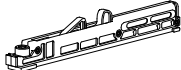

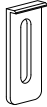
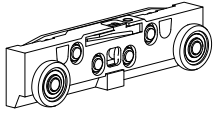

80 kg

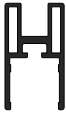
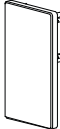
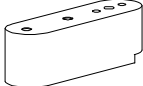

10 mm

N°		KG
1	 Nitne	80
2		80
3		80
4		80
5		80
6		80
7		80
8		80
9		80

N°		KG
10		80
11		80
12		80
13		80
14		80
15		80
16		80
17		80
18		



Nitne

PATENTIRANO

# Šema vrata sa maskom

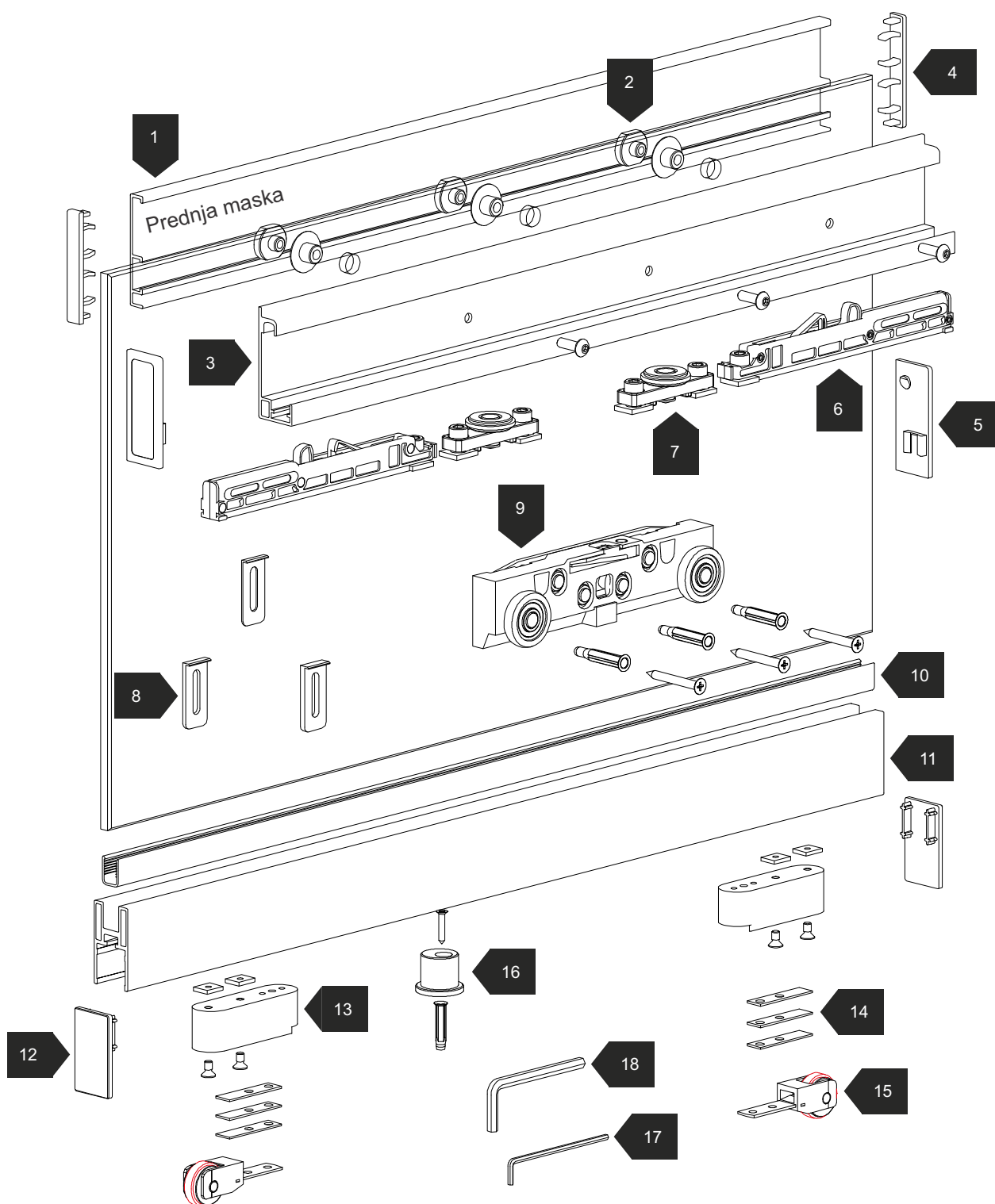







800 mm ÷ 1100 mm



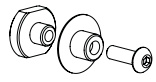



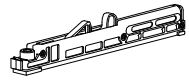

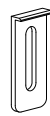
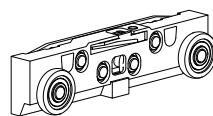

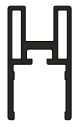
80 kg

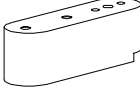

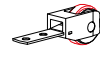
10 mm

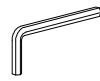
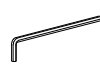
N°		KG
1	 Prednja maska	80
2		80
3		80
4		80
5		80
6		80
7		80
8		80
9		80

N°		KG
10		80
11		80
12		80
13		80
14		80
15		80
16		80
17		80
18		80

A modern glass sliding door system is shown in a room with a wooden floor. The door is partially open, revealing a black chair and white curtains in the background. A red circular stamp with the word 'PATENTIRANO' is located in the bottom right corner. A label 'Prednja maska' with a line pointing to the top edge of the glass panel is in the upper right.

**Prednja  
maska**

**PATENTIRANO**





# Magic Staklo

## Magic za staklena vrata

 Max 80 Kg

 Vazdušni usporivači

 Patentiran sistem

 Prilagodljiva širina vrata

 Set sa nitnama

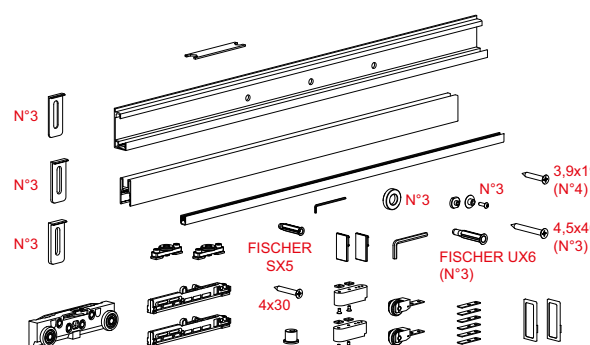
NAZIV		SET SA NITNAMA
<p>Magic set za staklena pregradna vrata sa nitnama, do 80kg.</p> <p>Šifra: 4066</p>	1100mm	 <p>                     N°3                      N°3                      N°3                      FISCHER SX5                      4x30                      N°3                      N°3                      3,9x19 (N°4)                      4,5x40 (N°3)                      FISCHER UX6 (N°3)                 </p>

 Max 80 Kg

 Vazdušni usporivači

 Patentiran sistem

 Prilagodljiva širina vrata

 Set sa maskom

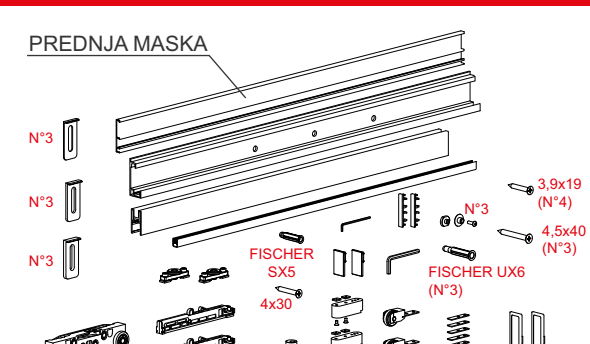
NAZIV		SET SA MASKOM
<p>Magic set za staklena pregradna vrata sa maskom, do 80kg.</p> <p>Šifra: 4501</p>	1100mm	<p>PREDNJA MASKA</p>  <p>                     N°3                      N°3                      N°3                      FISCHER SX5                      4x30                      N°3                      N°3                      3,9x19 (N°4)                      4,5x40 (N°3)                      FISCHER UX6 (N°3)                 </p>

POLOŽAJ RUPA NA STAKLU I SKRAĆIVANJE AL PROFILA

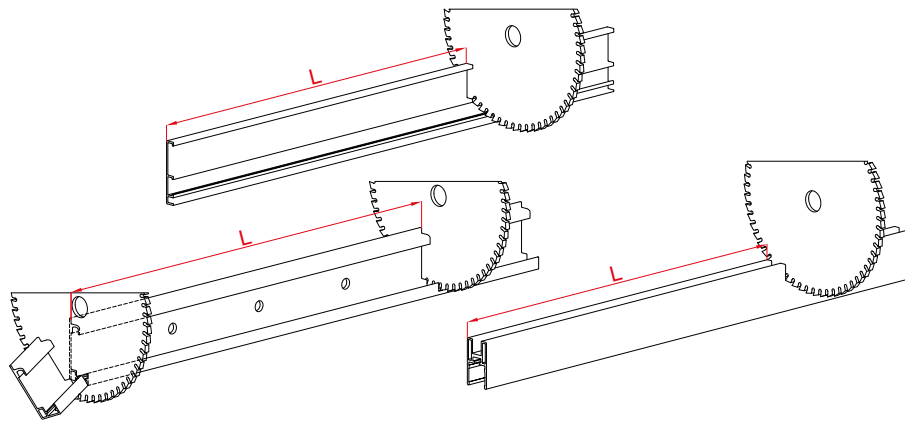
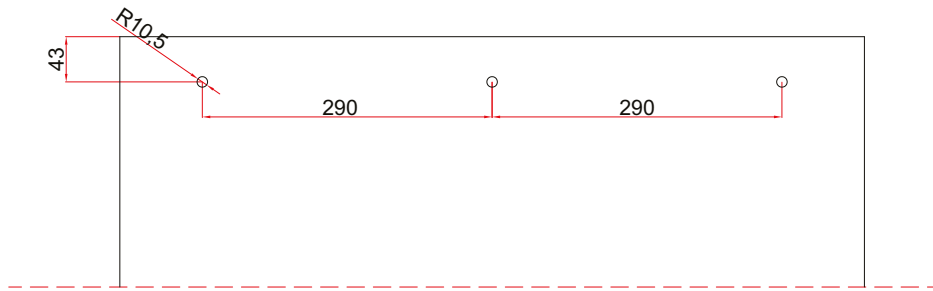

<p>čep</p>	<p>Prednja maska</p>	<p>čep</p>
<p>čep</p>	<p>Gornja šina</p>	<p>čep</p>
<p>čep</p>	<p>Donja šina</p>	<p>čep</p>

POSTAVLJANJE MEHANIZMA I IZRAČUNAVANJE DIMENZIJA ISPUNE

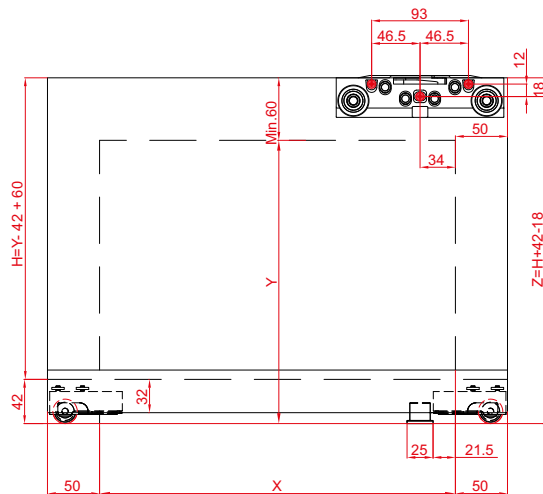
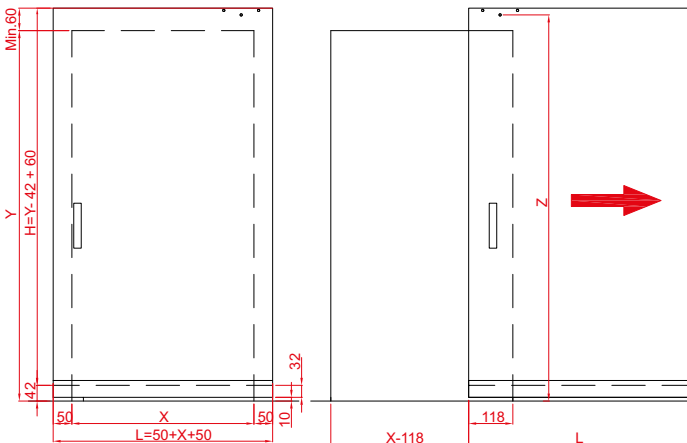

ART. MAGIC/1100  
 X= MIN. 700 ( L=800 )  
 X= MAX. 1000 ( L=1100 )

STANDARDNA POZICIJA VRATA U ODNOSU NA DATI OTVOR

POSTAVLJANJE MEHANIZMA I IZRAČUNAVANJE DIMENZIJA ISPUNE

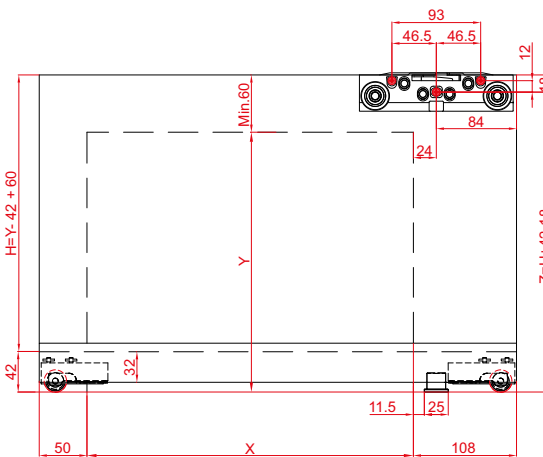
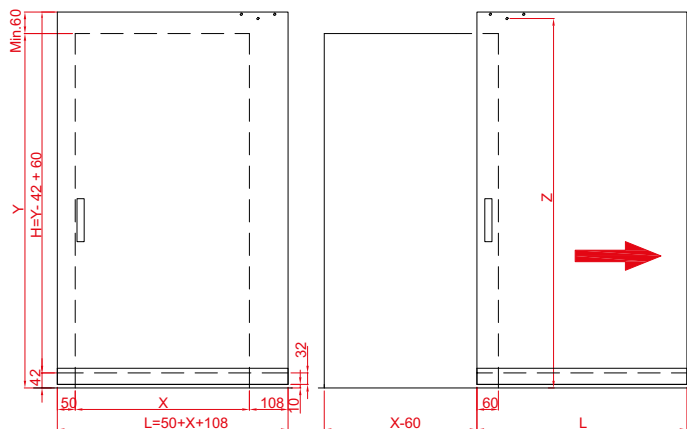

MAGIC/1100  
 X= MIN. 700 ( L=860 )  
 X= MAX. 940 ( L=1100 )

MEĐUPOZICIJA VRATA U ODNOSU NA DATI OTVOR

POSTAVLJANJE MEHANIZMA I IZRAČUNAVANJE DIMENZIJA ISPUNE

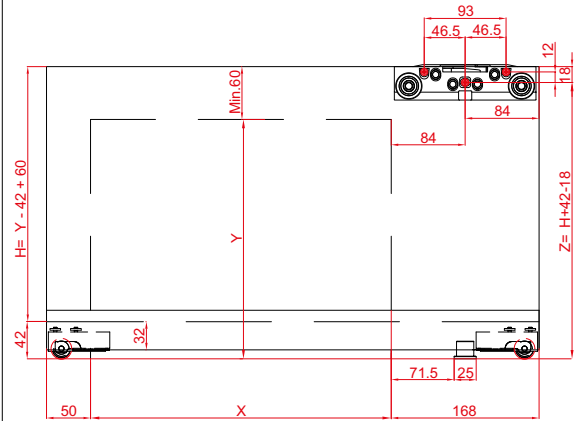
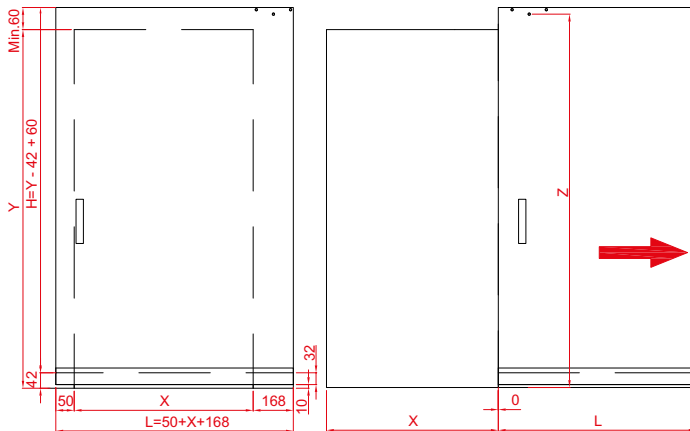

MAGIC/1100  
 X= MIN. 680 ( L=900 )  
 X= MAX. 880 ( L=1100 )

TOTALNO OTVARANJE VRATA U ODNOSU NA DATI OTVOR

OPIS I IZRAČUNAVANJE DIMENZIJA ISPUNE

