

Sistemi i profili za izradu kliznih plakarskih vrata

europrofil

SGC sistem za izradu drvenih plakarskih vrata

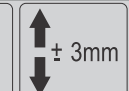
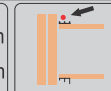

SGC 250 Meh.za spoljna vrata

SGC 450 Meh.za spoljna vrata

SGC 500 Meh.za spoljna vrata

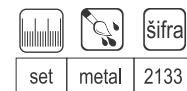
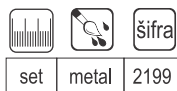

SGC Meh.za unutrašnja vrata

SGC usporivači za jedna vrata

SGC 8024 Donja šina AL

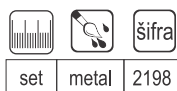
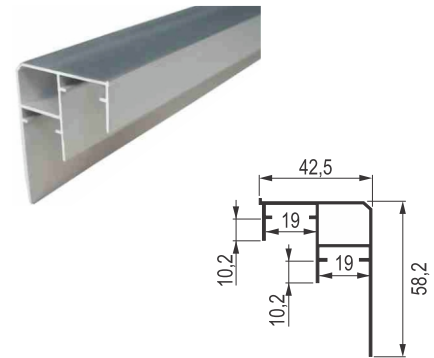

SGC 8025 Gornja šina AL

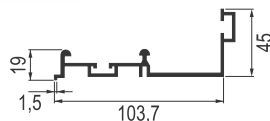
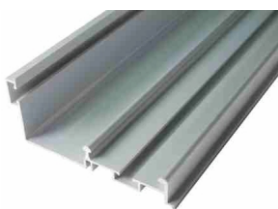

Napomena: SGC mehanizmi za spoljna vrata se dele na osnovu debljine ispune za koju su namenjeni:

SGC 250 - 20mm max.

SGC 450 - 30mm max.

SGC 500 - 40mm max.

Napomena: Ukoliko se uz SGC mehanizme postavljaju usporivači maksimalna težina vrata ne sme da prelazi 60 kilograma!

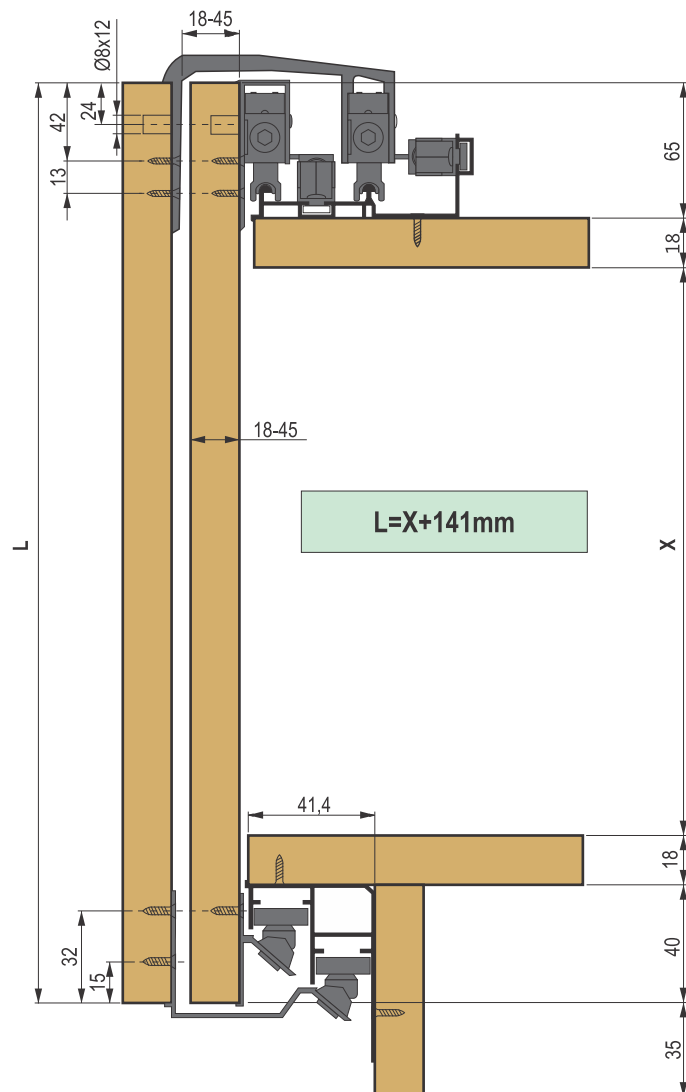
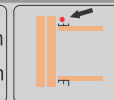
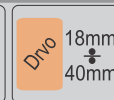

Postavljanje spoljašnjeg mehanizma

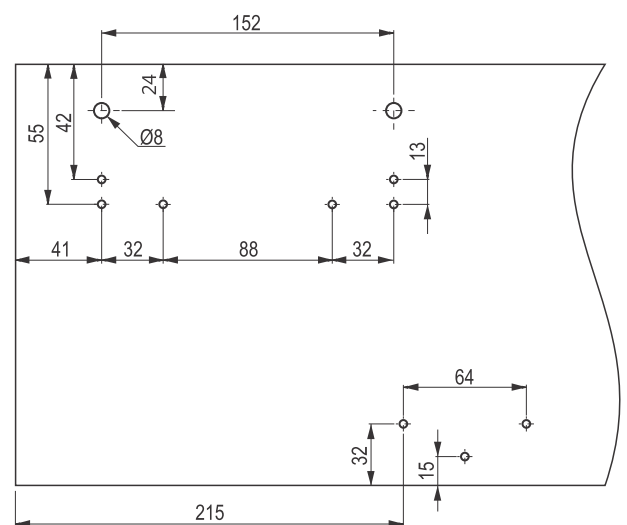

Postavljanje unutrašnjeg mehanizma

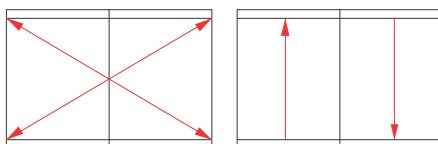
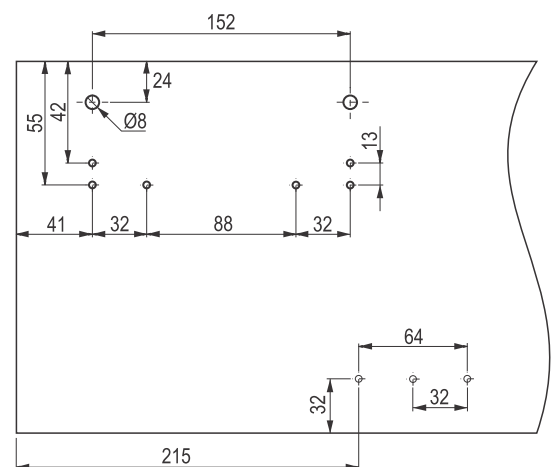

Tolerancija ± 1mm

Napomena: Nivelisanje dijagonala korpusa je obavezno!
Razmak između gornje ploče korpusa i donje ploče korpusa mora biti svugde isti.

