

EP-OP 09 Mehanizam za laka drvena klizna vrata nosivosti do 25 kg

Mehanizam EP-OP 09 koristi se kod izrade kliznih plakarskih vrata maksimalne nosivosti 25 kg. Za ovaj mehanizam koriste se jednokanalne donje i gornje šine od eloksiranog aluminijuma. Donji nosivi točkići su urađeni od tvrdog PVC-a sa kugličnim ležajevima, tako da prilikom rada omogućavaju skoro bešumno kretanje. Mehanizam ima mogućnost štelovanja vrata po visini +/- 3 mm. Mehanizam ne zahteva falcovanje ispune.

Predviđena debljina drvene ispune za dvoje vrata je 18mm.

Aluminijumske gornje i donje šine su 6m dužine.

Prodajne dimenzije Al gornje i donje šine: 1m; 1,5m; 2m; 3m; 4m i 6m.

Preporučeni rukohvati za ispunu debljine 18mm: SM-70, SM-35, SM-39, SM-39S, PKM-75F, SM-16.



EP-OP 09 Metalni mehanizam - set  
Šifra: 5536



EP-OP 09 Al gornja jednokanalna šina  
Šifra: 5537

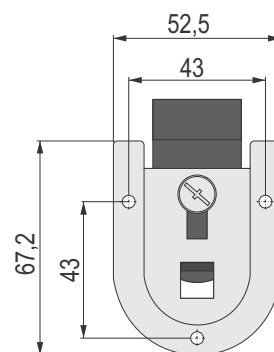
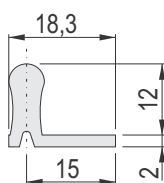

EP-OP 09 Al donja jednokanalna šina  
Šifra: 5538

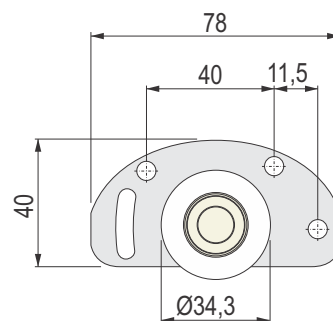
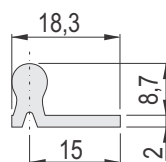

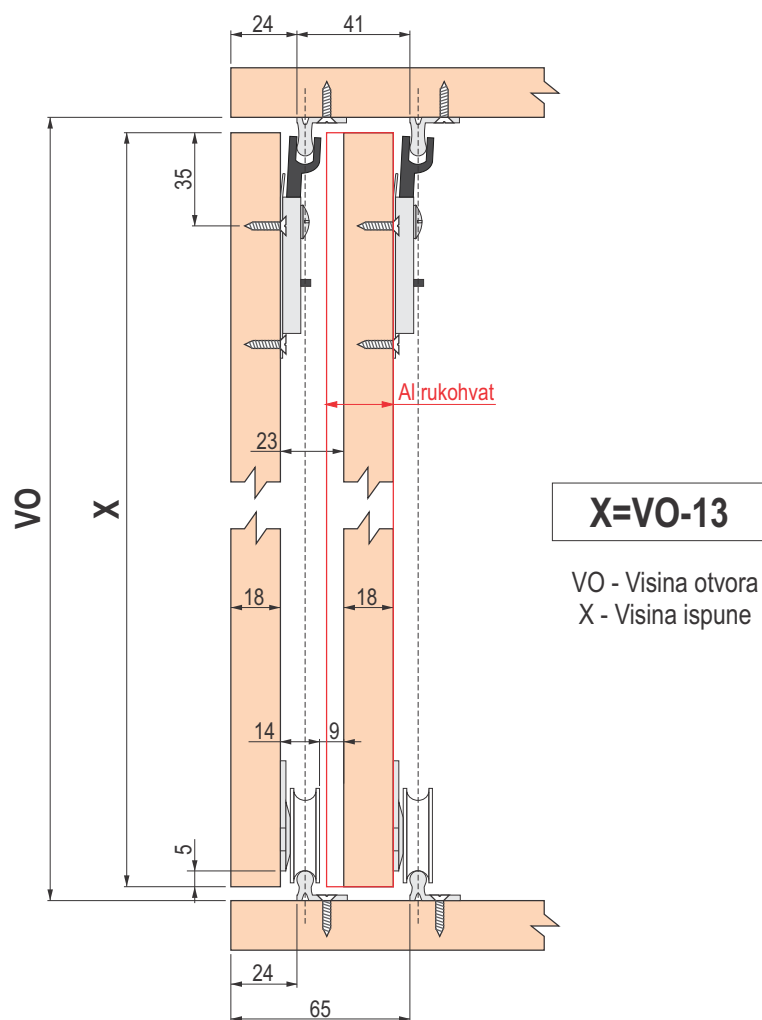

Šema montaže mehanizma sa ispunom debljine 18 mm

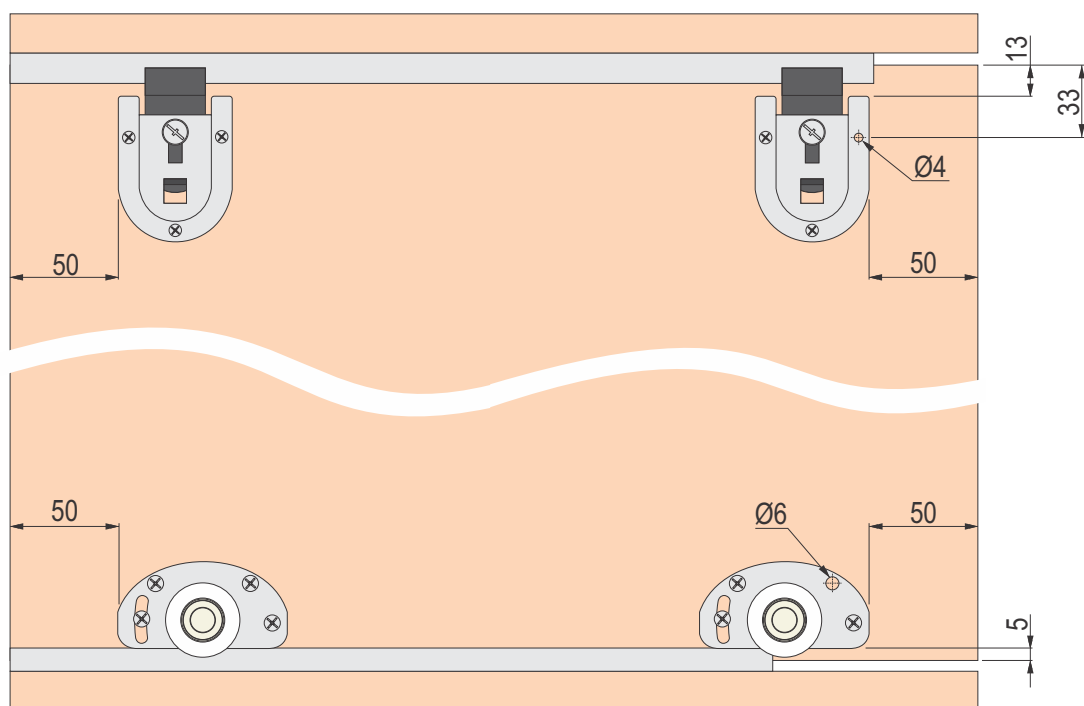

Preporučeni Al rukohvati i ukrutni profili

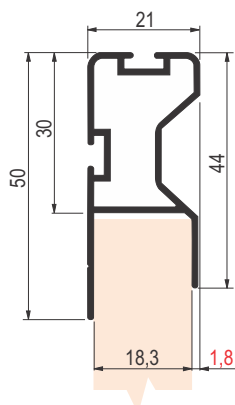

**75F**  
AL RUKOHVAT

		šifra
2,7m	mat srebro	880
2,7m	mat bronza	4289
2,7m	sjaj srebro	4713
2m, 3m	mat srebro	5210

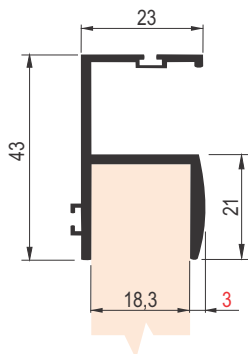

**SM - 39**  
AL RUKOHVAT

		šifra
2,7m	mat srebro	358
2,7m	mat bronza	2727
2,7m	sjaj srebro	4508
2m, 3m	mat srebro	5208

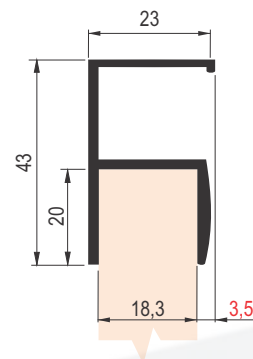

**SM - 39 S**  
AL RUKOHVAT

		šifra
2,7m	mat srebro	608
2m, 3m	mat srebro	5214

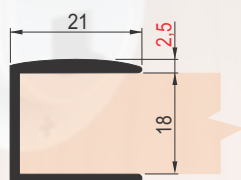

**SM - 35**  
AL UKRUTNI RUKOHVAT

		šifra
2,7m	mat srebro	167
2,7m	sjaj srebro	4516
2,7m	mat bronza	4517
2m, 3m	mat srebro	5209

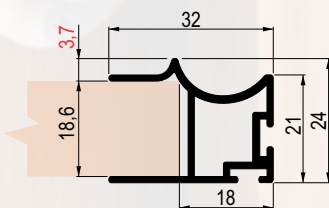

**SM - 70**  
AL UKRUTNI RUKOHVAT

		šifra
2,7m	mat srebro	4373
2,7m	sjaj srebro	2066
2,7m	mat bronza	2069

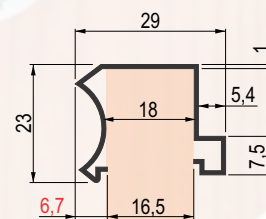

**SM - 16**  
AL UKRUTNI RUKOHVAT

		šifra
2,7m	mat srebro	5704
(2m; 3m)	mat srebro	5705